

Cisco SCE 2000 Series Service Control Engine

The Cisco® SCE 2000 Series Service Control Engine is a network element specifically designed for carrier-grade deployments requiring high-capacity stateful application and session-based classification and control of application-level IP traffic per subscriber.

Figure 1. Cisco SCE 2020 Service Control Engine



PRODUCT OVERVIEW

Service providers have an ever-increasing need to track subscriber traffic patterns, manage network bandwidth resources, and expand their service differentiation.

The Cisco SCE 2000 Series Service Control Engine is designed for carrier-grade deployments that require high-capacity stateful application- and session-based classification and control of all network traffic. Powered by a patented architecture employing hardware acceleration and multiple high-speed Reduced Instruction Set Computer (RISC) processors, the Cisco SCE 2000 Series is at the nucleus of the Cisco Service Control technology solution. It is a high-performance, purpose-built traffic metering and control device with a highly programmable core that can track and manage up to 2 million concurrent unidirectional application flows over an IP network. This extensible network element is specifically designed for scalable control of application flows.

Carriers and service providers deploy the Cisco SCE 2000 Series in high-performance metropolitan-area (metro), cable, DSL, mobile, or Wi-Fi networks to provide advanced application-level bandwidth optimization, management, and service control functions. The Cisco SCE 2000 Series resides at the edge of the network where two high-speed gigabit links are used for connecting aggregation access devices to the Internet backbone infrastructure.

Residing at this critical part of the network, the Cisco SCE 2000 Series has a multitude of carrier-grade features to help ensure nonstop network availability and overall IP service control. Two cascaded Cisco SCE 2000 Series engines can be deployed on dual gigabit links to achieve high availability and failover without imposing any single point of failure. To achieve higher performance and maximum capacity, the Cisco SCE 2000 Series takes advantage of patented system logic and stateful deep packet inspection analysis technology.

This solution provides state-based protocol monitoring that allows for the detection and control of virtually any network application, including: Web browsing, multimedia streaming, and peer-to-peer (P2P). The result is overall reduction of network congestion by optimizing application-level traffic, eliminating costly network link usage and infrastructure upgrades. Application and subscriber awareness become the foundation for the deployment of application tiers of service that can be based on content and premium IP service delivery.

Figure 2. Cisco Service Control Engine with Cisco Service Control Application

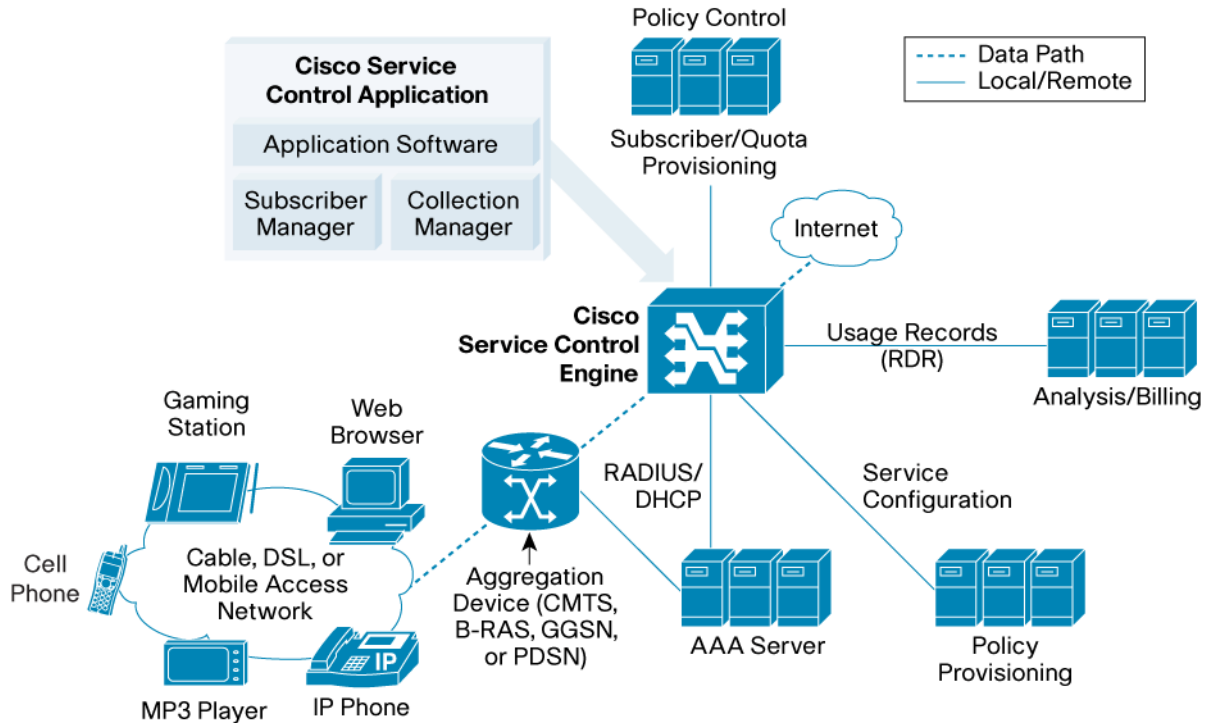

SERVICE APPLICATIONS

The Cisco SCE 2000 Series Service Control Engine is the highest-performing member of the Cisco SCE Family. Working with the Cisco Service Control Application for Broadband, it supports application-level classification of IP traffic for the real-time control of content-based services for a given subscriber or group. This solution offers programmable application detection and subscriber awareness.

KEY BENEFITS

Superior Performance

Cisco Service Control solutions analyze the payload of individual packets using stateful deep packet inspection at Layer 3–7. The Cisco SCE 2000 Series is an advanced IP service control solution offering throughput and capacity to support wire-speed processing of 4 Gbps of traffic over 2 gigabit links supporting 2 million unidirectional flows and using customized ASICs and hardware acceleration to help ensure carrier-grade performance.

10 Gigabit and Multi-Gigabit Solution

The Cisco SCE2000 serves as the foundation for Cisco’s deep packet inspection solution for multi-gigabit and 10 gigabit speeds, making Cisco the industry’s first in implementing service control functionality for these very fast network connections.

A group of Cisco SCE 2000s can be connected to Cisco 7600s or Catalyst 6500s providing 10 gigabit or multi-gigabit links, and then used for load-balancing the IP traffic, while ensuring that the traffic of each IP flow and subscriber is processed by the same Cisco SCE 2000. This breakthrough solution protects the investment in existing Cisco gear, and delivers scalability by inserting additional SCE 2000s as traffic increases for implementing a pay-as-you-grow strategy (Figure 3).

Figure 3. 10 Gigabit and Multi-Gigabit Solution

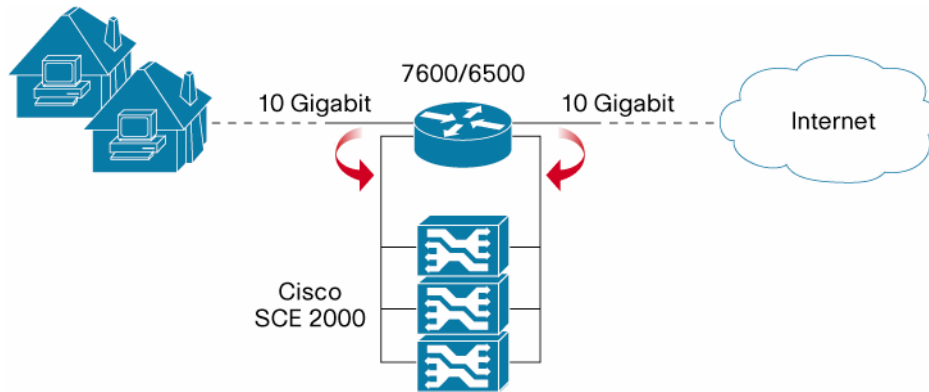

Stateful Deep Packet Inspection

Instead of processing packets as individual events, the Cisco SCE 2000 Series fully reconstructs individual traffic flows and the Layer 7 state of each individual application flow. By maintaining state information, the Cisco SCE 2000 Series readily identifies applications that employ dynamically assigned port numbers, and tracks applications that involve multiple inter-related or spawned flows commonly found in voice-over-IP (VoIP) or multimedia streaming protocols. The Cisco Service Control Engine applies rules as part of controlling the admission policies or session characteristics of a data flow.

Application level classification of IP traffic helps ensure real-time analysis and control of content-based services for a given subscriber or group of subscribers. Real-time advanced control functions include granular bandwidth shaping, quota, and redirection that uses protocol-specific, state-based traffic flow analysis.

High Availability

The performance requirements of a carrier-grade network demand that all network elements be capable of 24-hour operation. High availability is managed by using two Cisco SCE 2000 Series Service Control Engines in a unique cascading configuration overlaying dual gigabit links, without imposing any single point of failure. The primary Cisco SCE 2000 Series processes IP traffic of the two links while sharing state information with the secondary engine, which takes over if an interruption in the operation of the primary platform occurs. This unique architecture provides for stateful deep packet inspection in network environments with asymmetrical traffic flows.

Programmability

The Cisco SCE 2000 Series is programmable and extensible, helping to ensure that the solution can be readily adapted to new protocols and IP traffic-management requirements. SML, a programming language specifically developed for service delivery, can adapt the Cisco SCE Engines to the dynamic requirements of application-level analysis and traffic optimization while enabling the system to identify and manage complex protocols such as Session Initiation Protocol (SIP) and Real Time Streaming Protocol (RTSP).

The programmability of the Cisco SCE 2000 Series helps ensure that carriers can protect their network investments and adapt their service control infrastructure to meet the changing needs of new and emerging protocols and applications. This results in a decrease in the total cost of ownership of the Cisco SCE 2000 Series because capital equipment and operational costs can be further reduced by deploying a flexible, extensible network element for overall service control of application traffic.

Integration and Management

The Cisco SCE 2000 Series Service Control Engine integrates with existing network infrastructure, management, provisioning, operation, and support systems using industry-standard APIs.

Powerful management and infrastructure supporting the CLI and SNMP for configuration, monitoring, and fault management are provided to facilitate transparent deployment and interoperability. Extensible Markup Language (XML)- and GUI-based interfaces are provided for service management and delivery.

FEATURES

The Cisco SCE 2000 Series manages a wide variety of IP traffic while providing the highest throughput and supporting the greatest number of concurrent subscribers of any competitive offering in its class. Additionally, the system is equipped to provide failover protection, helping to ensure that no single point of failure exists for management of application-level traffic. This powerful solution is provided in a compact, 2-rack unit (RU) form factor (Table 1).

Table 1. Cisco SCE 2000 Series Features

Feature	Benefit
Traffic Handling	
Programmable Protocol Detection	<ul style="list-style-type: none"> • More than 600 protocols supported • Extensible to emerging protocols • Adaptive peer-to-peer (P2P) recognition
Tunneling Support and Stateful Layer 7 Deep Packet Inspection	<ul style="list-style-type: none"> • Multiprotocol Label Switching traffic engineering (MPLS-TE) • MPLS-VPN • VLAN • Layer 2 Tunneling Protocol (L2TP)
Differentiated Classes of Service (CoSs)	Support for: <ul style="list-style-type: none"> • Differentiated Services (DiffServ) • Type-of-service (ToS) byte
Capacity and Performance	
Maximum Throughput	4 Gbps
Number of Concurrent Subscribers	Up to 80,000
Simultaneous Unidirectional Flows	Up to 2,000,000
Reliability, Availability, and Serviceability (RAS) and Failover	
High Availability	Dual-cascaded system design to provide redundancy and failover protection
System Bypass for Link Preservation	<ul style="list-style-type: none"> • Internal electrical bypass mechanism (one per Gigabit Ethernet link) • Support for external optical bypass module (one per Gigabit Ethernet link)
Field-Replaceable Units	<ul style="list-style-type: none"> • Power supplies • Fan unit
Internal Redundancy	<ul style="list-style-type: none"> • Redundant power supplies • Redundant fans
Line Feeds	Dual AC and DC power
Integration and Management	
Integration	Industry-standard application programming interfaces (APIs) to ensure easy integration with: <ul style="list-style-type: none"> • Provisioning systems • Operations support systems (OSSs) • Management systems • Billing systems
Management	Powerful management capabilities offering: <ul style="list-style-type: none"> • GUI-based interfaces for service management • Command-line interface (CLI) and Simple Network Management Protocol (SNMP) interfaces for configuration, monitoring, and fault management

PRODUCT SPECIFICATIONS

Table 2. Product Specifications of Cisco SCE 2000 Series Service Control Engine

Specification	Description
Models	Cisco SCE 2020 Service Control Engine
Management Interfaces	2 x 10 / 100 / 1000 Mbps Ethernet RJ-45
Console Interface	2 x RS-232 RJ-45
Interfaces	4-port Gigabit Ethernet 1000BASE (SC): SX, 850 nm or LX, 1310 nm
Weight	33.1 lb (15 kg)
Dimensions (H x W x D)	3.54 x 17.3 x 18 in. (9 x 44 x 46 cm)
Temperature	Nominal 41 to 104°F (5 to 40°C), short term range 23 to 131°F (-5 to +55°C)
Humidity	5 to 95 percent (noncondensing)
Power	<ul style="list-style-type: none">• 100–240 VAC; 47–63 Hz; 200W• –36 to –72 VDC; 200W AC/DC; 683 BTU/hour; 2 PSUs with dual line feeds
Cooling and Airflow	Redundant cooling fans
EMC	FCC part 15, Full CE Mark, EN500 82-1
Safety	UL 60950, ULC 60950, IEC 60950
Telecom Safety Compliance	NEBS Level 3 approved, ETS 300-019

ORDERING INFORMATION

Table 3. Ordering Information for Cisco SCE 2000 Series Service Control Engine

Product Name	Part Number
Cisco SCE 2020 Multimode Chassis, 4 Multimode GBE Interfaces	SCE2020-4XGBE-MM
Cisco SCE 2020 Single-Mode Chassis, 4 Single-Mode GBE Interfaces	SCE2020-4XGBE-SM
Cisco Service Control Application View Only	SCA-BB-VO-R3
Cisco Service Control Application Capacity Control	SCA-BB-CC-R3
Cisco Service Control Application Tiered Control	SCA-BB-TC-XXX-R3*

* XXX represents number of subscribers: 10K, 50K, 250K, or 1M

SERVICE AND SUPPORT

Cisco Systems® offers a wide range of services programs to accelerate customer success. These innovative services programs are delivered through a unique combination of people, processes, tools, and partners, resulting in high levels of customer satisfaction. Cisco services help you to protect your network investment, optimize network operations, and prepare your network for new applications to extend network intelligence and the power of your business. For more information about Cisco Services, refer to [Cisco Technical Support Services](#) or [Cisco Advanced Services](#).

FOR MORE INFORMATION

For more information about Cisco Service Control, visit <http://www.cisco.com/>.



Corporate Headquarters
Cisco Systems, Inc.
170 West Tasman Drive
San Jose, CA 95134-1706
USA
www.cisco.com
Tel: 408 526-4000
800 553-NETS (6387)
Fax: 408 526-4100

European Headquarters
Cisco Systems International BV
Haarlerbergpark
Haarlerbergweg 13-19
1101 CH Amsterdam
The Netherlands
www-europe.cisco.com
Tel: 31 0 20 357 1000
Fax: 31 0 20 357 1100

Americas Headquarters
Cisco Systems, Inc.
170 West Tasman Drive
San Jose, CA 95134-1706
USA
www.cisco.com
Tel: 408 526-7660
Fax: 408 527-0883

Asia Pacific Headquarters
Cisco Systems, Inc.
168 Robinson Road
#28-01 Capital Tower
Singapore 068912
www.cisco.com
Tel: +65 6317 7777
Fax: +65 6317 7799

Cisco Systems has more than 200 offices in the following countries and regions. Addresses, phone numbers, and fax numbers are listed on the **Cisco.com Website at www.cisco.com/go/offices.**

Argentina • Australia • Austria • Belgium • Brazil • Bulgaria • Canada • Chile • China PRC • Colombia • Costa Rica • Croatia • Cyprus • Czech Republic
Denmark • Dubai, UAE • Finland • France • Germany • Greece • Hong Kong SAR • Hungary • India • Indonesia • Ireland • Israel • Italy
Japan • Korea • Luxembourg • Malaysia • Mexico • The Netherlands • New Zealand • Norway • Peru • Philippines • Poland • Portugal
Puerto Rico • Romania • Russia • Saudi Arabia • Scotland • Singapore • Slovakia • Slovenia • South Africa • Spain • Sweden
Switzerland • Taiwan • Thailand • Turkey • Ukraine • United Kingdom • United States • Venezuela • Vietnam • Zimbabwe

Copyright © 2006 Cisco Systems, Inc. All rights reserved. CCSP, CCVP, the Cisco Square Bridge logo, Follow Me Browsing, and StackWise are trademarks of Cisco Systems, Inc.; Changing the Way We Work, Live, Play, and Learn, and iQuick Study are service marks of Cisco Systems, Inc.; and Access Registrar, Aironet, BPX, Catalyst, CCDA, CCDP, CCIE, CCIP, CCNA, CCNP, Cisco, the Cisco Certified Internetwork Expert logo, Cisco IOS, Cisco Press, Cisco Systems, Cisco Systems Capital, the Cisco Systems logo, Cisco Unity, Enterprise/Solver, EtherChannel, EtherFast, EtherSwitch, Fast Step, FormShare, GigaStack, HomeLink, Internet Quotient, IOS, IP/TV, iQ Expertise, the iQ logo, iQ Net Readiness Scorecard, LightStream, Linksys, MeetingPlace, MGX, the Networkers logo, Networking Academy, Network Registrar, Packet, PIX, Post-Routing, Pre-Routing, ProConnect, RateMUX, ScriptShare, SlideCast, SMARTnet, The Fastest Way to Increase Your Internet Quotient, and TransPath are registered trademarks of Cisco Systems, Inc. and/or its affiliates in the United States and certain other countries.

All other trademarks mentioned in this document or Website are the property of their respective owners. The use of the word partner does not imply a partnership relationship between Cisco and any other company. (0601R)