



DATA SHEET

CISCO ONS 15302 MULTISERVICE PROVISIONING PLATFORM FOR SDH ACCESS NETWORKS

The Cisco® ONS 15302 Multiservice Provisioning Platform (MSPP) provides a simple solution for Ethernet and TDM service delivery to the customer premises. Together with the Cisco ONS 15305 and Cisco ONS 15454 SDH Multiservice Provisioning Platforms, the Cisco ONS 15302 provides an end-to-end solution for multiservice transport over SDH networks.

PRODUCT OVERVIEW

The Cisco ONS 15302 is a terminal multiplexer that extends the optical access network to the customer premises. With an STM-1 uplink to SDH optical networks, the Cisco ONS 15302 can collect voice and data traffic for switched services, Internet access, and VPNs. In only 1 rack unit (RU), the Cisco ONS 15302 combines data and voice traffic by transporting Ethernet and TDM channels inside an SDH STM-1 frame. A Layer 2 switch fabric allows native 10/100BASE-T Ethernet mapping into up to four virtual container groups (VCG) for point-to-point or point-to-multipoint transport over the SDH network. VCG bandwidth can be configured in as little as 2-Mbps increments.

Figure 1

Front and Rear Views of the Cisco ONS 15302 MSPP



The Cisco ONS 15302 management solution is based on an embedded Simple Network Management Protocol (SNMP) agent. A local craft interface called Cisco Edge Craft and the element management system, Cisco Transport Manager, allow remote supervision and provisioning for Cisco ONS 15302 devices. The Cisco ONS 15302 also provides a simple VT100 command-line interface (CLI) for initial setup and direct management of the unit. Administrators can manage the system by accessing it locally via the VT100 RS-232 port or the dedicated Ethernet management port. Remote access is possible via IP Point-to-Point Protocol (PPP)-based data communications network (DCN) or in band via one of the LAN or WAN ports.

APPLICATIONS

Multiservice Delivery

The Cisco ONS 15302 offers a small form factor (only 1 RU) and is capable of terminating traditional TDM and native Ethernet traffic, making it an ideal service-delivery device. As shown in Figure 2, traffic from up to 12 E1 and 4 10/100 Mbps Ethernet interfaces can be collected in a single Cisco ONS 15302 unit to be transported back to the first point of traffic aggregation on the service provider network. For Ethernet services, bandwidth can be configured individually for each LAN port in 2-Mbps increments. This allows service providers to deliver different levels of service based on each customer's needs.

Figure 2

Cisco ONS 15302 as a Multiservice Delivery Platform

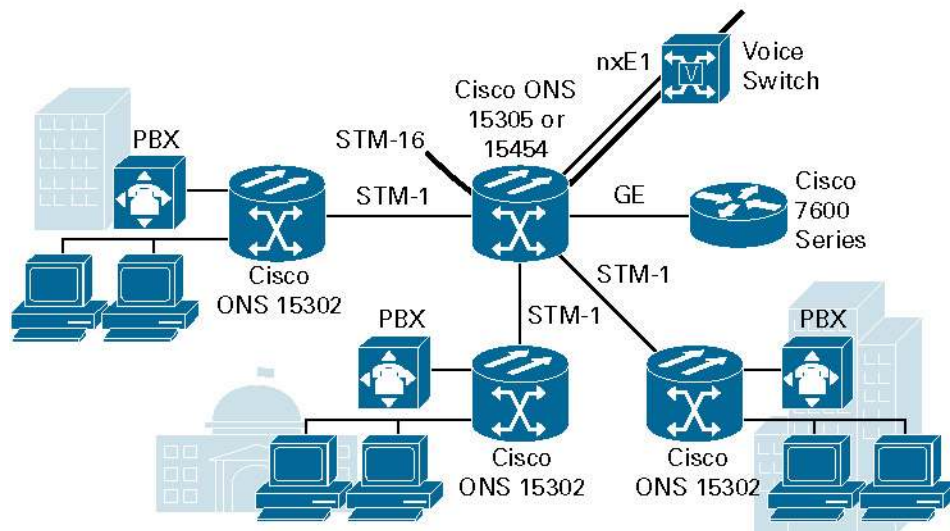

Enterprise Private Networks

The Cisco ONS 15302 can serve as an optical transport platform for enterprise private networks. A Cisco ONS 15305 device located at the headquarters or main building of an office, university, or government campus can aggregate Ethernet and TDM traffic from multiple remote sites (Figure 3) where Cisco ONS 15302 units are used as termination devices. A similar application takes place in high-rise buildings where a Cisco ONS 15305 can serve as a hub to distribute traffic via an optical backbone network to Cisco ONS 15302 terminals in different floors (Figure 4).

Figure 3
Metropolitan or Campus Enterprise Network

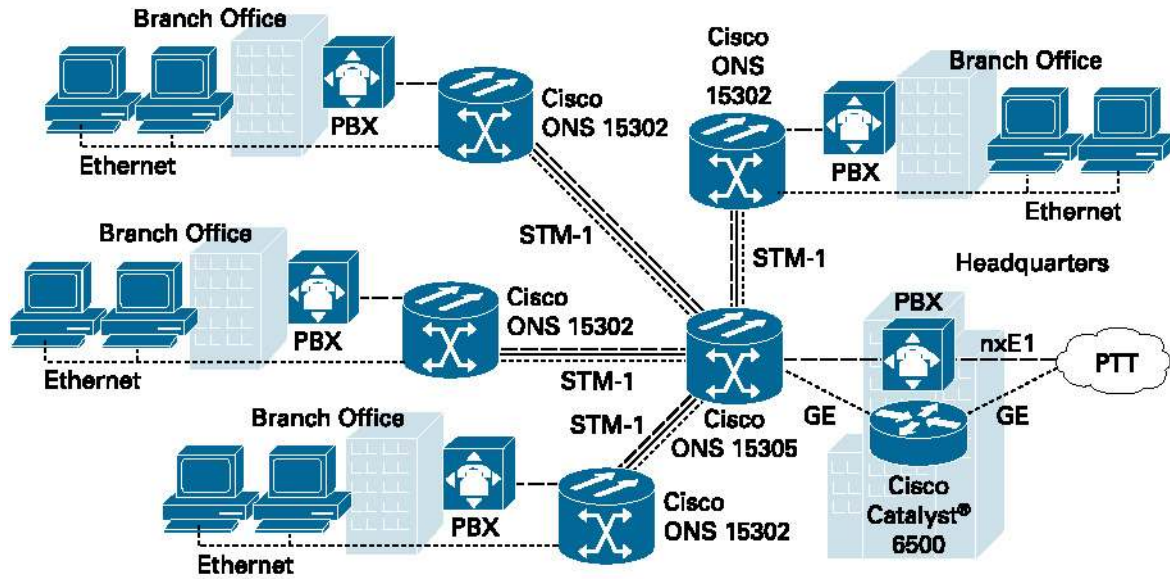
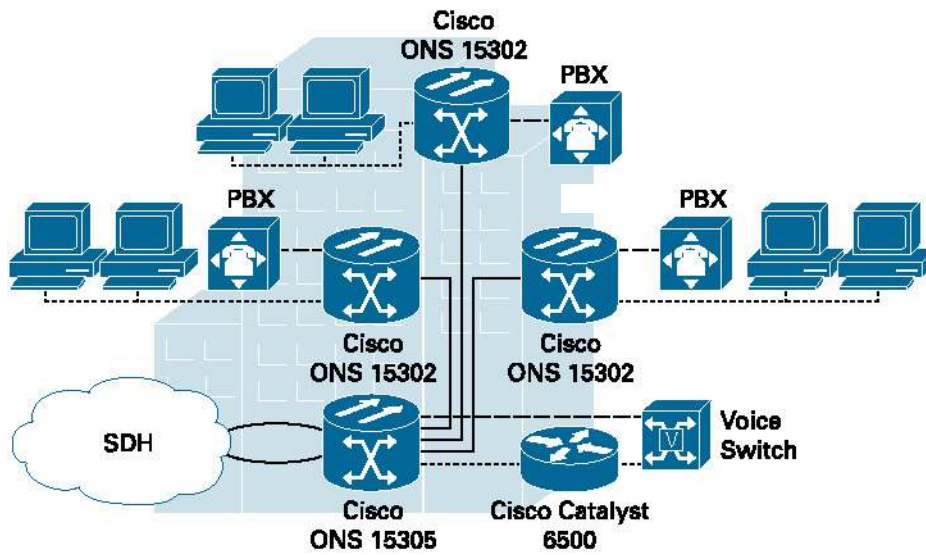

Figure 4
Enterprise Network in a High-Rise Building



KEY FEATURES AND BENEFITS

Ethernet over SDH Standards Compliance

The Cisco ONS 15302 offers ITU-T G.7041-compliant Generic Framing Procedure (GFP) encapsulation of Ethernet traffic for easy integration with existing SDH networks. The product also uses ITU-T G.707-compliant low-order and high-order virtual concatenation and ITU-T G.7042-compliant link capacity adjustment scheme (LCAS), making it more effective for scalable, next-generation optical infrastructures.

Integrated Layer 2 Switching

The Cisco ONS 15302 has an integrated Layer 2 switch that permits advanced management of packets for various applications and network configurations, such as data-traffic aggregation, and multipoint connections.

Flexible Network Topologies

The Cisco ONS 15302 can deliver traditional E1 services as well as native Ethernet traffic to the customer premises over unprotected or linear 1+1 MSP-protected STM-1 links. Ethernet bandwidth can be configured individually on each LAN port, only limited by the WAN capacity, which can be up to a full STM-1. Bandwidth can be added individually per port in 2-Mbps increments up to a maximum of 100 Mbps for Fast Ethernet. Many applications involve a simple point-to-point connection - either directly or through an SDH network - between two Cisco ONS 15302 units over an STM-1 circuit. Also, several branch offices can be connected to a headquarters location in a point-to-multipoint topology, where each branch can have individually dedicated bandwidth. Additional branches can be added by stacking units at headquarters. This “hub-and-spoke” topology is shown in Figure 5.

Figure 5

Point-to-Multipoint Connections over an SDH Infrastructure

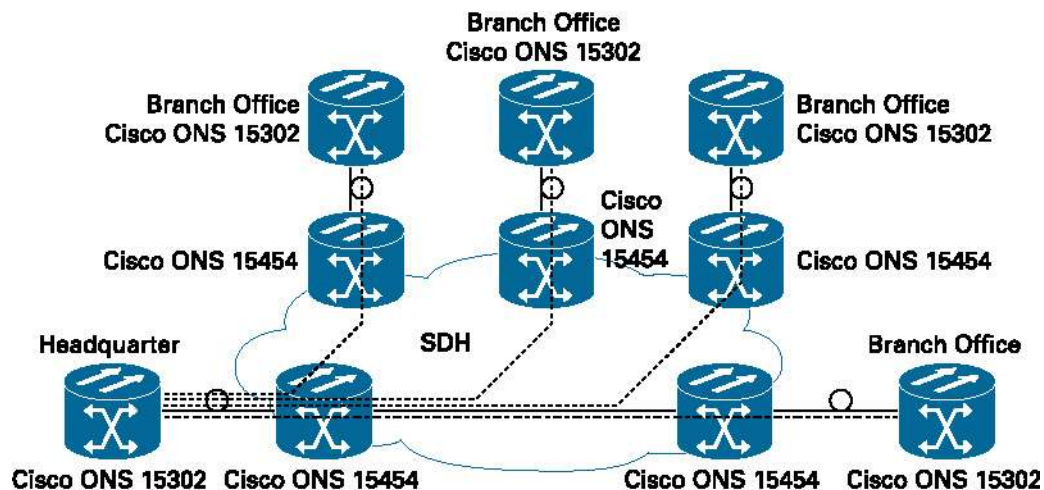

Simplified Management for All Cisco Optical Platforms

The Cisco ONS 15302 is managed by the Cisco Transport Manager element management system (EMS), which integrates all Cisco optical products under a single screen for network management. Cisco Transport Manager can indicate alarms and events of Cisco ONS 15302 devices in customer networks. Cisco Transport Manager can also display G.826 performance-monitoring parameters recorded by the Cisco ONS 15302 counters. Additionally, Cisco Transport Manager can cross-launch the Cisco ONS 15302 and Cisco ONS 15305 craft tool, the Cisco Edge Craft, to configure and provision Cisco ONS 15302 network elements.

SUMMARY/CONCLUSION

The Cisco ONS 15302 MSPP facilitates transport of Ethernet and time-division multiplexing (TDM) traffic over optical networks. The simple approach to integrate Layer 2 Ethernet intelligence with embedded optical transport technology allows cost-effective delivery of advanced Ethernet and traditional TDM services using an existing SDH infrastructure. This consolidation eliminates duplicate operations, administration, maintenance, and provisioning costs in the service provider infrastructure. Together with the Cisco ONS 15454 and the Cisco ONS 15305, the Cisco ONS 15302 provides an end-to-end solution for multiservice transport over SDH networks that can be monitored and provisioned on a single Cisco Transport Manager EMS screen.

PRODUCT SPECIFICATIONS

The tables below show the technical specifications of the Cisco ONS 15302.

Table 1. Optical Interfaces

Description	Specification
Compliance	ITU-T G.707 - Optical line signal ITU-T G.783 - Rx pull in and hold range ITU-T G.813 - Output jitter ITU-T G.825&G.958 - Input jitter ITU-T G.957 - Transmission
S1.1 optical interface	Source type: Laser diode Wavelength: 1260 - 1360 nm Modulation: 155,520 kbps Transmit power: -8 dBm maximum, -12 dBm minimum Receiver: -30 dBm sensitivity (BER < 1 in 10 ¹⁰) 0 dBm minimum overload Connectors: SC

Table 2. Electrical Interfaces

Description	Specification
E1 - 12 x 2 Mbps G.703 and ISDN Primary Rate Access (PRA)	Bit rate: 2048 kbps ± 50 ppm Line code: HDB3 Input jitter: According to ITU-T G.823 Output jitter: According to ITU-T G.783 Termination: 120 ohms on RJ-45 connectors (75 ohms with external balun)

Table 3. Data Interfaces

Description	Specification
Ethernet/LAN 4 x 10/100BASE-T	Compliance: According to IEEE 802.3 Connector: RJ-45 type

Table 4. Ethernet Features

Description	Specification
Ethernet Layer 2 switching	<ul style="list-style-type: none"> MAC switching Self-learning MAC addresses Static MAC entries Support of up to 24,000 MAC addresses Automatic aging for MAC addresses MAC multicast Supports up to 6144-byte frames Support for up to 9216-byte frames in Layer 1 mode Transparent bridging IEEE 802.1Q VLAN tagging 802.1q in 802.1q Layer 2 Control Protocol tunneling Head-of-line blocking prevention Back pressure and flow-control handling IGMP support Spanning Tree Protocol according to IEEE 802.1D RSTP according to IEEE 802.1w Mirroring port IEEE 802.1p priorities
Ethernet over SDH transport	<ul style="list-style-type: none"> ITU-T G.7041 Generic Framing Procedure (GFP) ITU-T G.707 Virtual Concatenation VC-12-Xv, X=1-50; VC-3-Xv, X=1-3, VC-4 ITU-T G.7042 Link Capacity Adjustment Scheme (LCAS)

Table 5. Performance Monitoring

Description	Specification
Compliance	ITU-T G.826
MS/RS PM-STM-n	B1 near end, B2 near and far end
VC-3 and VC-4	B3 near and far end
VC-12	BIP-2 near and far end

Table 6. Timing

Description	Specification
Sources	STM-1, 2048 kHz synchronization input, E1 tributary (PRA)
Output	2048-kHz synchronization output (output signal balance according to ETS 300 126)
Connector	One 8-pin RJ-45 for both input and output

Table 7. External Alarm Ports

Description	Specification
Connector	One 9-pin D-type connector
Input	4 ports
Output	2 ports

Table 8. Power

Description	Specification
DC power	-36 VDC to -72 VDC (-48 VDC nominal)
AC power	AC: 230 VAC +/-10%
Dissipation	< 25W fully loaded without WAN module, < 40W with WAN plug-in module

Table 9. Safety and Environmental

Description	Specification
EMC	EN 55022 Class B and EN 50082-1
Safety	EN 60950 and EN 60825
Temperature	Thermal requirement: EN 60950 Operating temperature: (-5 to 45°C) according to ETS 300 019-1-3, Class 3.2 Storage: ETS 300 019-2-1, Class 1.1 Transport: ETS 300 019-2-2, Class 2.2

Table 10. Network Management

Description	Specification
Craft tool	Cisco Edge Craft
EMS	Cisco Transport Manager

Table 11. Physical Dimensions

Description	Specification
H x W x D	43 x 445 x 240 mm (1 RU)
Weight	< 4 kg

ORDERING INFORMATION

To place an order, visit the Cisco Ordering Home Page.

Table 12. Cisco ONS 15302 Ordering Information

Product Name	Part Number
Cisco ONS 15302 Unprotected SC, STM1-SH, Release 2.0 Software, Ship-Kit	15302-U-R2.0-SC=
Cisco ONS 15302 Protected SC, STM1-SH, Release 2.0 Software, Ship-Kit	15302-P-R2.0-SC=
Cisco ONS 15302 Unprotected SC, STM1-SH, Release 2.0 Software, Ship-Kit and WAN R2	15302-U-R2.0-SC-W=
Cisco ONS 15302 Protected SC, STM1-SH, Release 2.0 Software, Ship-Kit and WAN R2	15302-P-R2.0-SC-W=
Cisco ONS 15302 System Documentation Release 2.0.0, English, CD	15302-DOC2.0.0CD=
Cisco ONS 15302 Software Release 2.0 Feature Package, CD	15302-R2.0.0SWCD=
Cisco ONS 15302 Ship Kit	15302-SHIPKIT-A=
Cisco ONS 15302 Cisco Edge Craft Management Tool, R2.0.0	15302-R2.0.0-CEC=

SERVICE AND SUPPORT

Cisco offers a wide range of services programs to accelerate customer success. These innovative services programs are delivered through a unique combination of people, processes, tools, and partners, resulting in high levels of customer satisfaction. Cisco services help you to protect your network investment, optimize network operations, and prepare the network for new applications to extend network intelligence and the power of your business. For more information about Cisco Services, see [Cisco Technical Support Services](#) or [Cisco Advanced Services](#).

FOR MORE INFORMATION

For more information about the Cisco ONS 15302, visit <http://www.cisco.com/en/US/products/hw/optical/ps2001/ps5116/index.html> or contact your local account representative.

**Corporate Headquarters**

Cisco Systems, Inc.
170 West Tasman Drive
San Jose, CA 95134-1706
USA
www.cisco.com
Tel: 408 526-4000
800 553-NETS (6387)
Fax: 408 526-4100

European Headquarters

Cisco Systems International BV
Haarlerbergpark
Haarlerbergweg 13-19
1101 CH Amsterdam
The Netherlands
www-europe.cisco.com
Tel: 31 0 20 357 1000
Fax: 31 0 20 357 1100

Americas Headquarters

Cisco Systems, Inc.
170 West Tasman Drive
San Jose, CA 95134-1706
USA
www.cisco.com
Tel: 408 526-7660
Fax: 408 527-0883

Asia Pacific Headquarters

Cisco Systems, Inc.
168 Robinson Road
#28-01 Capital Tower
Singapore 068912
www.cisco.com
Tel: +65 6317 7777
Fax: +65 6317 7799

Cisco Systems has more than 200 offices in the following countries and regions. Addresses, phone numbers, and fax numbers are listed on **the Cisco Website at www.cisco.com/go/offices.**

Argentina • Australia • Austria • Belgium • Brazil • Bulgaria • Canada • Chile • China PRC • Colombia • Costa Rica
Croatia • Cyprus • Czech Republic • Denmark • Dubai, UAE • Finland • France • Germany • Greece • Hong Kong SAR
Hungary • India • Indonesia • Ireland • Israel • Italy • Japan • Korea • Luxembourg • Malaysia • Mexico
The Netherlands • New Zealand • Norway • Peru • Philippines • Poland • Portugal • Puerto Rico • Romania • Russia
Saudi Arabia • Scotland • Singapore • Slovakia • Slovenia • South Africa • Spain • Sweden • Switzerland • Taiwan
Thailand • Turkey • Ukraine • United Kingdom • United States • Venezuela • Vietnam • Zimbabwe

Copyright © 2004 Cisco Systems, Inc. All rights reserved. Catalyst, Cisco, Cisco Systems, and the Cisco Systems logo are registered trademarks or trademarks of Cisco Systems, Inc. and/or its affiliates in the United States and certain other countries.

All other trademarks mentioned in this document or Website are the property of their respective owners. The use of the word partner does not imply a partnership relationship between Cisco and any other company. (0406R)
Pa/LW6927 11/04