

## Cisco ME 4924-10GE Ethernet Aggregation Switch

The Cisco® ME 4924-10GE Switch is a next-generation Layer 3 user-facing premise equipment (UPE) aggregation device purposely built for high-performance Carrier Ethernet networks. Based on Cisco Catalyst® 4900 Series Switch technology, the Cisco ME 4924 delivers on the performance, availability, and form factor required in residential broadband triple-play service aggregation and business Ethernet deployments.

### Product Overview

The Cisco ME 4924 (Figure 1) is the first switch optimized for UPE aggregation based on Cisco Catalyst 4900 Series technology. It provides the line-rate performance required to deliver data, voice, and video services to thousands of subscribers simultaneously. Service providers have the choice of uplinking to a 10 GE or 1 GE backbone using a variety of Small Form-Factor Pluggable (SFP) and X2 optic types.

**Figure 1.** Cisco ME 4924-10GE Switch



### Configuration

- Twenty-four Gigabit Ethernet SFP User to Network Interfaces (UNI) and four Gigabit Ethernet SFP uplinks/ trunk ports with an additional two 10 Gigabit Ethernet X2 uplinks
- Redundant field-replaceable AC and DC power supplies
- Removable fan tray with redundant fans
- 1 rack unit (RU) form factor

The Cisco ME 4924 comes standard with the IP Base Software image (Table 1). This image includes the Layer 2 feature set, as well as Routing Information Protocol (RIP) and Enhanced Interior Gateway Routing Protocol (EIGRP) stub support.

For greater service breadth and network flexibility, the Cisco ME 4924 supports the Enterprise Services image, which provides advanced Layer 3 features such as advanced IP routing protocols, including: RIPv1 and 2, EIGRP, Open Shortest Path First (OSPF), Border Gateway Protocol Version 4 (BGPv4), and Intermediate System-to-Intermediate System (IS-IS).

**Table 1.** Software Configuration Options for the Cisco ME 4924-10GE Switch

Software Image	Description
<b>IP Base Image</b>	Standard Layer 3 image, including RIPv1 and v2, static routes, includes EIGRP stub
<b>Enterprise Services Image</b>	Enhanced Layer 3 image, includes OSPF, IS-IS, EIGRP, and Border Gateway Protocol (BGP), AppleTalk, and Internetwork Packet Exchange (IPX) software routing. Also includes all IP Base Image features.

SFP-based Gigabit Ethernet ports accommodate a wide range of 1000BASE-X SFP transceivers. The options include Cisco 1000BASE-T, 1000BASE-SX, 1000BASE-LX, 1000BASE-ZX, and coarse wavelength-division multiplexing (CWDM) SFP transceivers.

The Cisco Metro Ethernet switching portfolio includes the industry-leading Cisco ME 6524, ME 3750, and ME 3400 Series intelligent Ethernet switches. By using Cisco ME switches for metro access and aggregation along with Cisco Catalyst 6500 and Catalyst 4500 Series Switches and Cisco 7600 Series routers in the aggregation/core layers, service providers can build a flexible, integrated network with end-to-end intelligence.

### Applications

Metro Ethernet aggregation switches are typically deployed in central office locations. Service providers are often challenged to find enough space to deploy equipment. To ease this obstacle, the Cisco ME 4924 is designed with a compact form factor (1RU). In addition, it is built with high-performance 10 Gigabit Ethernet uplinks to further reduce the space required to deliver triple-play services to residential customers. A typical broadband service deployment contains customer premise equipment (CPE) connected to large UPE nodes that aggregate hundreds of individual users. High performance UPE network nodes have fiber GE uplinks that connect to PE-aggregation devices like the Cisco ME 4924. PE-aggregation devices need to aggregate traffic from thousands of users and uplink to the Network Provider Edge (NPE). Figure 2 shows a typical SP network.

**Figure 2.** Service Provider Network

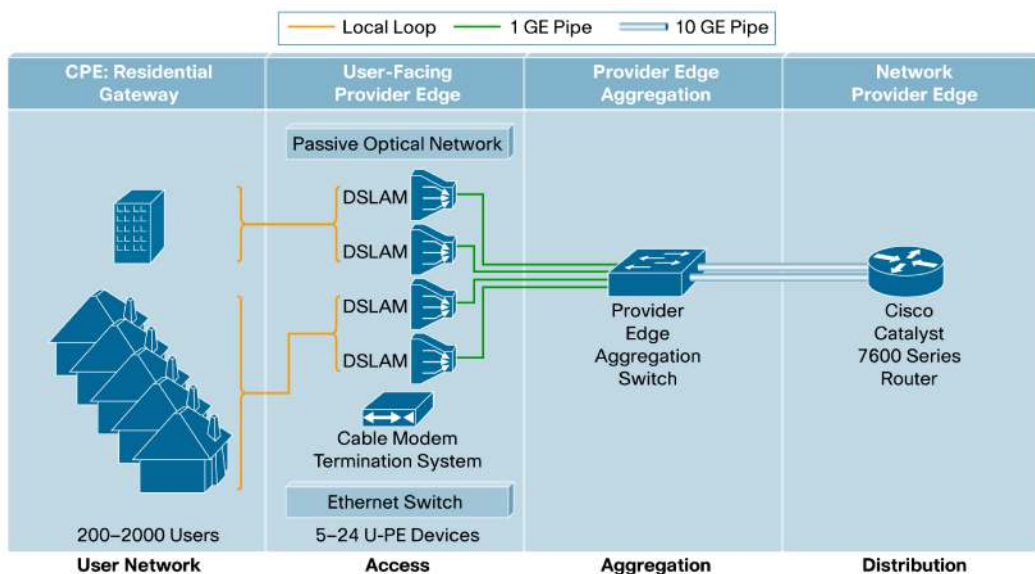

### Triple-Play Service

Triple-play service is a popular choice for service providers. By combining Internet access, voice, and video services into a single unified offering, service providers can generate higher average revenue per user (ARPU) and increase customer retention. The Cisco ME 4924 is optimized for triple-play service. By delivering essential features in the areas of QoS, multicast, and security, the Cisco ME 4924 helps service providers increase their competitive edge by deploying successful triple-play services.

### Increased Service Availability

The Cisco ME 4924 can be equipped with an optional redundant power supply, available in both AC and DC versions. The power supply redundancy gives service providers an immediate failover capability in the case of a power supply or circuit failure. Power redundancy decreases the chance of service outage and allows the service provider to offer a service-level agreement (SLA) with a higher level of service availability.

The power supplies for the Cisco ME 4924 are also field-replaceable and hot-swappable, allowing service providers to replace a failed power supply without interrupting their customers' service. The redundant power supplies built into the Cisco ME 4924 enable service providers to build a resilient, highly available network.

### Security

The Cisco ME 4924 supports a comprehensive set of security features for connectivity and access control, including access control lists (ACLs), authentication, port-level security, and identity-based network services with 802.1x and extensions. The ACLs allow service providers to restrict unwanted traffic into their networks by denying packets based on source and destination MAC addresses, IP addresses, or TCP/User Datagram Protocol (UDP) ports. All ACL lookups are done in hardware, so forwarding and routing performance is not compromised when implementing ACL-based security in the network.

### Key Features and Benefits

Table 2 describes the key features and benefits of the Cisco ME 4924.

**Table 2.** Key Features and Benefits of Cisco ME 4924-10GE Switch

Features	Benefits
<b>Purpose-Built Next-Generation Ethernet Aggregation Switch</b>	<ul style="list-style-type: none"> <li>• Compact form factor (1RU) allows for deployment in space-constrained areas.</li> <li>• Support for SFP and X2 transceivers provides flexible uplink options.</li> <li>• Both AC and DC power options are available.</li> </ul>
<b>Triple-Play Services</b>	<ul style="list-style-type: none"> <li>• 10 GE uplinks allow for easy delivery of high-bandwidth services such as video on demand and high-definition TV (HDTV).</li> </ul>
<b>High-Performance IP Routing</b>	<ul style="list-style-type: none"> <li>• Basic IP Unicast routing protocols (static and RIPv1 and v2) are supported for small-network routing applications.</li> <li>• Advanced IP Unicast routing protocols (OSPF, EIGRP, and BGPv4) are supported for load balancing and constructing scalable networks.</li> <li>• Hot Standby Router Protocol (HSRP) provides dynamic load balancing and failover for routed links.</li> </ul>
<b>Intelligent QoS and Traffic Management</b>	<ul style="list-style-type: none"> <li>• Sharing, shaping, and strict-priority configurations determine scheduling of egress traffic.</li> </ul>
<b>Wire-Speed Performance in All Directions</b>	<ul style="list-style-type: none"> <li>• High-performance switching is maintained regardless of the number of route entries or Layer 3 and Layer 4 services enabled.</li> </ul>

### Product Architecture

#### Based on the Catalyst 4900 Series Switching Engine

The Cisco ME 4924 shares the same packet processing engine as the Catalyst 4900 Series. This processing engine allows for ultralow latency and predictable performance regardless of the number and type of services enabled.

### Wire-Speed Performance in All Directions

The Cisco ME 4924 delivers wire-speed throughput with low latency for data-intensive applications using a 48-Gbps switching fabric with a forwarding rate of 71 million packets per second (mpps) in hardware for Layer 2–4 traffic. High-performance switching is maintained regardless of the number of route entries or Layer 3 and 4 services enabled. Hardware-based Cisco Express Forwarding routing architecture allows for increased scalability and performance. X2 10 Gigabit Ethernet optics provide 20 Gigabit Ethernet wire-speed uplinks for maximum throughput of traffic over high-performance backbone rings.

### Service Management Options

The Cisco ME 4924 offers a superior command-line interface (CLI) for detailed configuration. In addition, it supports CiscoWorks and the Simple Network Management Protocol (SNMP) for networkwide management. Service providers can integrate the Cisco ME 4924 transparently into their OSS and enable improved flow-through provisioning.

### Technical Specifications

#### Performance and Switching Specifications

- 48-Gbps nonblocking switch fabric
- 71-mpps Layer 2 forwarding (hardware)
- 71-mpps Layer 3 and 4 forwarding—IP routing, Cisco Express Forwarding-based (hardware)
- Layer 2–4 hardware-based switch engine (application-specific integrated circuit [ASIC]-based)
- Unicast and multicast routing entries: 32,000
- Support for 4096 active VLANs and 4096 VLAN IDs per switch
- Layer 2 multicast addresses: 16,000
- MAC addresses: 32,000
- Policers: 512 ingress and 512 egress
- ACL or QoS entries: 32,000
- Uplinks: Four SFP ports and two X2 ports with support of Cisco Gigabit EtherChannel<sup>®</sup> technology
- Switched virtual interfaces (SVIs): 2048
- Internet Group Management Protocol (IGMP) snooping entries: 8000
- Scalability to 1500 Spanning Tree Protocol instances
- Bandwidth aggregation up to 16 Gbps through Cisco Gigabit EtherChannel technology
- Hardware-based wire-speed multicast management
- Hardware-based wire-speed ACLs

#### Layer 2 Features

- Layer 2 switch ports and VLAN trunks
- IEEE 802.1Q VLAN encapsulation
- Inter-Switch Link (ISL) VLAN encapsulation
- Dynamic Trunking Protocol (DTP)

- VLAN Trunking Protocol (VTP) and VTP domains
- Per-VLAN Spanning Tree Protocol Plus (PVST+) and Per-VLAN Rapid Spanning Tree Protocol (PVRST)
- Spanning-tree PortFast and PortFast guard
- Spanning-tree UplinkFast and BackboneFast
- 802.1s
- 802.1w
- Spanning-tree root guard
- Cisco Discovery Protocol
- IGMP snooping v1, v2, and v3
- 802.3ad
- Cisco EtherChannel technology, Cisco Fast EtherChannel technology, and Cisco Gigabit EtherChannel technology support
- Port Aggregation Protocol (PAgP)
- Unidirectional Link Detection Protocol (UDLD) and aggressive UDLD on the SFP ports
- Q-in-Q in hardware
- Layer-2 Protocol Tunneling (L2PT)
- Jumbo frames on all ports (up to 9216 bytes)
- Baby giants (up to 1600 bytes)
- Hardware-based storm control (formally known as broadcast and multicast suppression)
- Community private VLANs (PVLANS)
- Forced 10/100 autonegotiation
- Web Content Communication Protocol Version 2 Layer 2 Redirect
- Private VLAN Promiscuous Trunk

### Layer 3 Features

- Static IP routing
- IP routing protocols: EIGRP, OSPF, RIP, RIP2
- BGPv4 and Multicast Border Gateway Protocol (MBGP)
- Hot Standby Router Protocol (HSRP)
- Software routing of IPX and AppleTalk
- IS-IS routing protocol
- IGMPv1, v2, and v3
- IGMP filtering on access and trunk ports
- IP Multicast routing protocols (Protocol Independent Multicast [PIM], Source Specific Multicast [SSM], and Distance Vector)
- Multicast Routing Protocol (DVMRP)
- Pragmatic General Multicast (PGM)
- Cisco Group Management Protocol (GMP) server
- Full Internet Control Message Protocol (ICMP) support
- ICMP Router Discovery Protocol

- Policy-based routing (PBR)
- Virtual Route Forwarding-lite (VRF-lite)
- IPv6 software switching support
- OSPF fast convergence
- EIGRP stub
- Virtual Router Redundancy Protocol (VRRP)

### **Sophisticated QoS and Traffic Management**

- Per-port QoS configuration
- Per-port per-VLAN QoS
- Support for four queues per port in hardware
- Strict priority queuing
- Classification and marking based on IP type of service (ToS) or DSCP
- Classification and marking based on full Layer 3 and 4 headers (IP only)
- Input and output policing based on Layer 3 and 4 headers (IP only)
- Support for 512 policers on ingress and 512 policers on egress configured as aggregate or individual
- Shaping and sharing output queue management
- Dynamic Buffer Limiting (DBL): Advanced congestion avoidance
- No performance penalty for granular QoS functions

### **Comprehensive Management**

- Manageable through CiscoWorks network-management software on a per-port and per-switch basis, providing a common management interface for Cisco routers, switches, and hubs
- Manageable through Cisco Network Assistant
- SNMPv1, v2, and v3 instrumentation, delivering comprehensive in-band management
- CLI-based management console to provide detailed out-of-band management
- Remote Monitoring (RMON) software agent to support four RMON groups (history, statistics, alarms, and events) for enhanced traffic management, monitoring, and analysis
- Support for all nine RMON groups through the use of a Cisco SwitchProbe analyzer (Switched Port Analyzer [SPAN]) port, which permits traffic monitoring of a single port, a group of ports, or the entire switch from a single network analyzer or RMON probe
- Analysis support, including ingress port, egress port, and VLAN SPAN
- Remote SPAN (RSPAN)
- Smartports macros
- SPAN ACL filtering
- Dynamic Host Configuration Protocol (DHCP) client autoconfiguration
- Interface index (IfIndex) persistence
- HTTPS
- Time Domain Reflectometry (TDR)
- MAC address notification

### Advanced Security

- TACACS+ and RADIUS, which enable centralized control of the switch and restrict unauthorized users from altering the configuration
- 802.1x RADIUS-supplied timeout
- Standard and extended ACLs on all ports
- 802.1x user authentication (with VLAN assignment, port security, voice VLAN, and guest VLAN extensions)
- 802.1x accounting
- 802.1x authentication failure
- 802.1x Private VLAN assignment
- 802.1x Private Guest VLAN
- Trusted boundary
- Router ACLs (RACLs) on all ports (no performance penalty)
- VLAN ACLs (VACLs)
- Port ACLs (PACLs)
- PVLANS on access and trunk ports
- DHCP Snooping
- DHCP Option 82
- DHCP Option 82 insertion
- DHCP Option 82 pass through
- Port security
- Trunk port security
- Sticky port security
- Secure Shell (SSH) Protocol versions 1 and 2
- VLAN Management Policy Server (VMPS) client
- Unicast MAC filtering
- Unicast port flood blocking
- Dynamic Address Resolution Protocol (ARP) inspection
- IP Source Guard
- Community PVLAN
- Control Plane Policing
- 802.1x Unidirectional Controlled Port
- Voice VLAN Sticky Port Security
- Secure Copy Protocol (SCP)
- 802.1x Inaccessible Authentication Bypass
- MAC Authentication Bypass

**Traffic and Congestion Management**

- Number of queues: four queues per port
- Type of buffers: Dynamic

**Switch Architecture Specifications**

- Packet buffering: Dynamic, 16-MB shared memory
- CPU speed: 266 MHz
- Flash memory: 64 MB
- Synchronous dynamic RAM (SDRAM): 256 MB

**Management**

- CiscoWorks LAN Management Solution (LMS), including CiscoWorks Resource Manager Essentials
- CiscoView
- BGP4-MIB.my
- BRIDGE-MIB.my\* (RFC 1493)
- CISCO-BULK-FILE-MIB.my
- CISCO-CDP-MIB.my
- CISCO-CLASS-BASED-QOS-MIB.my
- CISCO-CONFIG-COPY-MIB.my
- CISCO-CONFIG-MAN-MIB.my
- CISCO-ENTITY-ASSET-MIB.my
- CISCO-ENTITY-EXT-MIB.my
- CISCO-ENTITY-FRU-CONTROL-MIB.my
- CISCO-ENTITY-SENSOR-MIB.my
- CISCO-ENTITY-VENDORTYPE-OID-MIB.my
- CISCO-ENVMON-MIB.my
- CISCO-FLASH-MIB.my
- CISCO-FTP-CLIENT-MIB.my
- CISCO-HSRP-MIB.my
- CISCO-IETF-IP-MIB.my
- CISCO-IETF-IP-FORWARD-MIB.my
- CISCO-IETF-ISIS-MIB.my
- CISCO-IF-EXTENSION-MIB.my
- CISCO-IGMP-FILTER-MIB.my
- CISCO-IMAGE-MIB.my
- CISCO-IPMROUTE-MIB.my
- CISCO-L2-TUNNEL-CONFIG-MIB.my
- CISCO-L2L3-INTERFACE-CONFIG-MIB.my
- CISCO-LAG-MIB.my
- CISCO-MEMORY-POOL-MIB.my

- CISCO-NDE-MIB.my
- CISCO-PAGP-MIB.my
- CISCO-PAE-MIB.my
- CISCO-PING-MIB.my
- CISCO-PORT-SECURITY-MIB.my
- CISCO-PORT-STORM-CONTROL-MIB.my
- CISCO-PRIVATE-VLAN-MIB.my
- CISCO-PROCESS-MIB.my
- CISCO-PRODUCTS-MIB.my
- CISCO-RF-MIB.my
- CISCO-RMON-CONFIG-MIB.my
- CISCO-RTTMON-MIB.my
- CISCO-STP-EXTENSIONS-MIB.my
- CISCO-SYSLOG-MIB.my
- CISCO-VLAN-IFTABLE-RELATIONSHIP-MIB.my
- CISCO-VLAN-MEMBERSHIP-MIB.my
- CISCO-VTP-MIB.my
- DOT3-MAU-MIB.my (RFC 3636)
- ENTITY-MIB.my
- ETHERLIKE-MIB.my
- EXPRESSION-MIB.my
- HC-RMON-MIB.my
- IEEE8021-PAE-MIB.my
- IEEE8023-LAG-MIB.my (802.3ad)
- IF-MIB.my
- IGMP-MIB.my
- IPMROUTE-MIB.my
- NOVELL-IPX-MIB.my
- NOVELL-RIP SAP-MIB.my
- OLD-CISCO-TS-MIB.my
- PIM-MIB.my
- RFC1213-MIB.my (MIB-II)
- RFC1243-MIB.my (APPLETALK MIB)
- RFC1253-MIB.my (OSPF-MIB)
- RMON-MIB.my (RFC 1757)
- RMON2-MIB.my (RFC 2021)
- SMON-MIB.my (Internet-Draft)
- SNMP-FRAMEWORK-MIB.my (RFC 2571)
- SNMP-MPD-MIB.my (RFC 2572)

- SNMP-NOTIFICATION-MIB.my (RFC 2573)
- SNMP-TARGET-MIB.my (RFC 2573)
- SNMP-USM-MIB.my (RFC 2574)
- SNMP-VACM-MIB.my (RFC 2575)
- SNMPv2-MIB.my
- TCP-MIB.my
- UDP-MIB.my
- RIP SNMP MIB

#### **Industry Standards**

- Gigabit Ethernet: IEEE 802.3z and 802.3ab
- IEEE 802.1d Spanning Tree Protocol
- IEEE 802.1w rapid reconfiguration of spanning tree
- IEEE 802.1s multiple VLAN instances of spanning tree
- IEEE 802.3ad Link Aggregation Control Protocol (LACP)
- IEEE 802.1p class-of-service (CoS) prioritization
- IEEE 802.1Q VLAN
- IEEE 802.1x user authentication
- 1000BASE-X (SFP)
- 1000BASE-SX
- 1000BASE-LX/LH
- 1000BASE-ZX
- RMON I and II standards

#### **Indicator and Port Specifications**

- Fan, PS1, PS2
- Power supply status: Green (operational), red (faulty)
- System status: Green (operational), red (faulty)
- Console: RJ-45 female
- SFP ports: Link
- Image management port: 10/100BASE-TX (RJ-45 female) data terminal equipment (DTE); green (good), orange (disabled), off (not connected)

## Supported SFP Transceivers

**Table 3.** SFP Transceivers Supported by

### SFP Transceivers

Gigabit Ethernet SFP, LC connector LH transceiver  
 Gigabit Ethernet SFP, LC connector SX transceiver  
 Gigabit Ethernet SFP, LC connector ZX transceiver  
 Gigabit Ethernet SFP, RJ-45 connector, 1000BASE-T transceiver  
 Cisco CWDM SFP 1470 nm; Gigabit Ethernet and 1G/2G Fibre Channel (FC) (grey)  
 Cisco CWDM SFP 1490 nm; Gigabit Ethernet and FC (violet)  
 Cisco CWDM SFP 1510 nm; Gigabit Ethernet and FC (blue)  
 Cisco CWDM SFP 1530 nm; Gigabit Ethernet and 1G/2G FC (green)  
 Cisco CWDM SFP 1550 nm; Gigabit Ethernet and FC (yellow)  
 Cisco CWDM SFP 1570 nm; Gigabit Ethernet and FC (orange)  
 Cisco CWDM SFP 1590 nm; Gigabit Ethernet and FC (red)  
 Cisco CWDM SFP 1610 nm; Gigabit Ethernet and FC (brown)

## Supported X2 Transceivers

**Table 4.** X2 Transceivers Supported by

### X2 Transceivers

10 Gigabit Ethernet X2, LR 10 km on single-mode fiber (SMF) (G.652)  
 10 Gigabit Ethernet X2, CX4 up to 15m on IBX4 cable  
 10 Gigabit Ethernet LX4 300m on multimode fiber (MMF)  
 10 Gigabit Ethernet SR 26 to 300m on MMF (depends on MMF type)  
 10 Gigabit Ethernet ER 40 km on SMF  
 10 Gigabit Ethernet X2, LR 10 km on single-mode fiber (SMF) (G.652)

## Power Supply Specifications

The Cisco ME 4924 offers a choice of 300-watt (W) AC or DC power supplies. The switch can operate with one power supply present. When two power supplies are installed, the switch shares the power load between the two supplies (Table 4).

**Table 5.** AC and DC Power Supply Specifications

Specification	300W AC	300W DC
Input Current	4A at 110V 2A at 220V	8A at -48 to -60V
Output Current	25A at 12 VDC	25A at 12 VDC
Weight	2.0 kg	2.0 kg
Heat Dissipation	1023 BTU per hour	1023 BTU per hour

## Switch Dimensions

- Width: 17.290 in. (43.9166 cm)
- Depth: 16.14 in. (40.9956 cm)
- Height: 1.712 in. (4.445 cm)
- Weight: 16.5 lb (7.48 kg) with one power supply

## Software Requirements

The Cisco ME 4924 is supported only in Cisco IOS® Software and is not supported in Cisco Catalyst OS Software. The minimum software release is Cisco IOS Software Release 12.2(31)SGA or later.

## Environmental Conditions

- Operating temperature: 32 to 104°F (0 to 40°C)
- Storage temperature: –40 to 167°F (–40 to 75°C)
- Relative humidity: 10 to 90 percent, noncondensing
- Operating altitude: –60 to 2000m

## Regulatory Standards Compliance

Table 6 lists the regulatory, safety, and EMC standards that are met by the Cisco ME 4924.

**Table 6.** Regulatory Standards Compliance

Specification	Description
<b>Regulatory Compliance</b>	Products bear CE Marking, indicating compliance with the 89/336/EEC and 73/23/EEC directives, which include the following safety and EMC standards.
<b>Safety</b>	<ul style="list-style-type: none"> <li>• UL 60950-1</li> <li>• CAN/CSA-C22.2 No. 60950-1</li> <li>• EN 60950-1</li> <li>• IEC 60950-1</li> <li>• AS/NZS 60950</li> <li>• IEC 60825-1</li> <li>• IEC 60825-2</li> <li>• EN 60825-1</li> <li>• EN 60825-2</li> <li>• 21 CFR 1040</li> </ul>
<b>EMC</b>	<ul style="list-style-type: none"> <li>• FCC Part 15 (CFR 47) Class A</li> <li>• ICES-003 Class A</li> <li>• EN55022 Class A</li> <li>• CISPR22 Class A</li> <li>• AS/NZS 3548 Class A</li> <li>• VCCI Class A</li> <li>• EN55024</li> <li>• ETS300 386</li> <li>• EN50082-1</li> <li>• EN61000-3-2</li> <li>• EN61000-3-3</li> </ul>

**Table 7.** NEBS and ETSI Specifications

Specification	Description
<b>Network Equipment Building Standards (NEBS)</b>	<ul style="list-style-type: none"> <li>• GR-63-Core NEBS Level 3</li> <li>• GR-1089-Core NEBS Level 3</li> </ul>
<b>European Telecommunications Standards Institute (ETSI)</b>	<ul style="list-style-type: none"> <li>• ETS 300 019 Storage Class 1.1</li> <li>• ETS 300 019 Transportation Class 2.3</li> <li>• ETS 300 019 Stationary Use Class 3.1</li> </ul>

## Warranty

The warranty for the Cisco ME 4924 is a one-year limited hardware warranty; it includes hardware replacement with a 10-day turnaround from receipt of a return materials authorization (RMA).

## Cisco Technical Support Services

Cisco Technical Support Services help to ensure that your Cisco products operate efficiently, remain highly available, and benefit from current system software to assist you in effectively managing your network service while controlling operational costs.

Cisco Technical Support Services provide significant benefits that go beyond what is offered under the Cisco warranty policy. Services available under a Cisco SMARTnet® service contract that are not covered under a warranty include the following (also refer to Tables 7 and 8):

- Latest software updates
- Rapid replacement of hardware in next-day, 4-hour, or 2-hour dispatch options
- Ongoing technical support through Cisco Technical Assistance Center (TAC)
- Registered access to [Cisco.com](http://Cisco.com)

## Ordering Information

To place an order, visit the [Cisco Ordering Home Page](#). Table 9 gives ordering information for the Cisco ME 4924.

**Table 8.** Ordering Information

Product Name	Part Number
Cisco ME 4924-10GE, IP Base software image (RIP, static routes), no power supply, fan tray	ME-4924-10GE
Cisco IOS Software for Cisco Catalyst 4900 Series switches (IP Base image)	S49IPB-12231SGA(=)
Cisco IOS Software for Cisco Catalyst 4900 Series switches (IP Base image with Triple Data Encryption Standard [3DES])	S49IPBK9-12231SGA(=)
Cisco IOS Software for Cisco Catalyst 4900 Series switches (Enterprise Services image with BGP support)	S49ES-12231SGA(=)
Cisco IOS Software for Cisco Catalyst 4900 Series switches (Enterprise Services image with 3DES and BGP support)	S49ESK9-12231SGA(=)
Cisco Catalyst 4900 300W AC power supply	PWR-C49-300AC(=)
Cisco Catalyst 4900 300W AC power supply, redundant	PWR-C49-300AC/2
Cisco Catalyst 4900 300W DC power supply	PWR-C49-300DC(=)
Cisco Catalyst 4900 300W DC power supply, redundant	PWR-C49-300DC/2
Cisco Catalyst 4900 fan tray (spare)	WS-X4991=
Spare rack-mount and cable guide	C4948-ACC-KIT=
C4948-BKT-KIT=	C4900 front and rear mount brackets
<b>Power Cable Options</b>	
AC Power Cord North America	CAB-7KAC
AC Power Cord (Australia)	CAB-7KACA
AC Power Cord (Europe)	CAB-7KACE
AC Power Cord CD12 (Italy)	CAB-7KACI
AC POWER CORD (Argentina)	CAB-7KACR
AC Power Cord (South Africa)	CAB-7KACSA
AC Power Cord (United Kingdom)	CAB-7KACU

Product Name	Part Number
<b>SFP Options</b>	
Gigabit Ethernet SFP, LC connector LH transceiver	GLC-LH-SM=
Gigabit Ethernet SFP, LC connector SX transceiver	GLC-SX-MM=
Gigabit Ethernet SFP, LC connector ZX transceiver	GLC-ZX-SM=
Gigabit Ethernet SFP, RJ-45 connector, 1000BASE-T transceiver	GLC-T=
1000BASE-BX10-D downstream bidirectional single fiber; with DOM	GLC-BX-D=
1000BASE-BX10-U upstream bidirectional single fiber; with DOM	GLC-BX-U=
Cisco CWDM SFP 1470 nm; Gigabit Ethernet and 1G/2G FC (gray)	CWDM-SFP-1470=
Cisco CWDM SFP 1490 nm; Gigabit Ethernet and FC (violet)	CWDM-SFP-1490=
Cisco CWDM SFP 1510 nm; Gigabit Ethernet and 1G/2G FC (blue)	CWDM-SFP-1510=
Cisco CWDM SFP 1530 nm; Gigabit Ethernet and 1G/2G FC (green)	CWDM-SFP-1530=
Cisco CWDM SFP 1550 nm; Gigabit Ethernet and 1G/2G FC (yellow)	CWDM-SFP-1550=
Cisco CWDM SFP 1570 nm; Gigabit Ethernet and 1G/2G FC (orange)	CWDM-SFP-1570=
Cisco CWDM SFP 1590 nm; Gigabit Ethernet and 1G/2G FC (red)	CWDM-SFP-1590=
Cisco CWDM SFP 1610 nm; Gigabit Ethernet and 1G/2G FC (brown)	CWDM-SFP-1610=
Cisco CSS 11500 10m fiber single-mode LX LC-to-SC connectors	CSS5-CABLX-LCSC=
Cisco CSS 11500 10m fiber multimode SX LC connectors	CSS5-CABSX-LC=
Cisco CSS 11500 10m fiber multimode SX LC-to-SC connectors	CSS5-CABSX-LCSC=
1m fiber single-mode LC-to-SC connectors	CAB-SM-LCSC-1M
5m fiber single-mode LC-to-SC connectors	CAB-SM-LCSC-5M
<b>X2 Options</b>	
10GBASE-CX4 X2 Module	X2-10GE-CX4
10GBASE-ER X2 Module	X2-10GE-ER
10GBASE-SR X2 Module	X2-10GE-SR
10GBASE-LX4 X2 Module	X2-10GE-LX4
10GBASE-LR X2 Module	X2-10GE-LR

## Service and Support

Cisco Systems® offers a wide range of services programs to accelerate customer success. These innovative services programs are delivered through a unique combination of people, processes, tools, and partners, resulting in high levels of customer satisfaction. Cisco services help you to protect your network investment, optimize network operations, and prepare the network for new applications to extend network intelligence and the power of your business. For more information about Cisco Services, see [Cisco Technical Support Services](#) or [Cisco Advanced Services](#).

## For More Information

For more information about the Cisco ME 4924-10GE, visit <http://www.cisco.com> or contact your local account representative.

