

Cisco ME 3400 Series Ethernet Access Switches

The Cisco® ME 3400 Series Ethernet Access Switches is a series of next-generation Layer 2 and Layer 3 customer-located devices purposely built for service providers. Its design is based on the experience learned from today's most widely deployed access switches, the Cisco Catalyst® 2950 Series and Catalyst 3550 Series.

Product Overview

As an addition to the Cisco Metro Ethernet access switching portfolio, which includes the industry-leading Cisco Catalyst 3550 and Cisco Catalyst 2950 series intelligent Ethernet switches, as well as the new Cisco ME 3400 Metro Ethernet Access Switches, the Cisco Catalyst 3750 Metro Series provides enhanced QoS, broader Layer 2 and Layer 3 VPN offerings, and power redundancy for carrier-class Metro Ethernet services with service-quality guarantees. By using Cisco Catalyst 3750 Metro Series switches for metro access along with Cisco Catalyst 6500 and 4500 series switches and Cisco 7600 Series routers in the aggregation/core layers, service providers are able to build a flexible, integrated network with intelligence from end to end.

The Cisco ME 3400 Series (Figure 1) includes the following configurations:

- **Cisco ME 3400G-12CS AC** with 12 dual-purpose (10/100/1000 and Small Form-Factor Pluggable [SFP]) ports, four SFP uplinks, and two fixed redundant AC power supplies (part number ME-3400G-12CS-A)
- **Cisco ME 3400G-12CS DC** with 12 dual-purpose (10/100/1000 and SFP) ports, four SFP uplinks, and two fixed redundant DC power supplies (part number ME-3400G-12CS-D)
- **Cisco ME 3400G-2CS AC** with two dual-purpose (10/100/1000 and SFP) ports, two SFP uplinks, and an AC power supply (part number ME-3400G-2CS-A)
- **Cisco ME 3400-24TS AC** with 24 Ethernet 10/100 ports, two SFP uplinks, and an AC power supply (part number ME-3400-24TS-A)
- **Cisco ME 3400-24TS DC** with 24 Ethernet 10/100 ports, two SFP uplinks, and a DC power supply (part number ME-3400-24TS-D)

Figure 1. Cisco ME 3400-24TS AC Ethernet Access Switch for 10/100 Access



The Cisco ME 3400 Series offers three Cisco IOS® Software feature images, METROBASE, METROACCESS, and METROIPACCESS. The METROBASE image offers advanced quality of service (QoS), rate limiting, robust multicast control, and comprehensive security features. The METROACCESS image provides a richer set of Metro Ethernet access features, including 802.1Q Tunneling, Layer 2 Protocol Tunneling (L2PT), and Flex-Link. The METROIPACCESS image provides advanced Layer 3 features such as advanced IP routing (Routing Information Protocol [RIP] versions 1 and 2, Enhanced Interior Gateway Routing Protocol [EIGRP], Open Shortest Path First [OSPF], Intermediate System-to-Intermediate System [IS-IS], and Border Gateway Protocol Version 4 [BGPv4]), Multi-VPN Routing and Forwarding Customer Edge [Multi-VRF CE], and Policy Based Routing (PBR). Options are also available to upgrade switches to a different version of the software feature image.

The SFP-based Gigabit Ethernet ports accommodate a wide range of 100BASE and 1000BASE SFP transceivers. The options include Cisco 100BASE-LX, 100BASE-FX, 100BASE-BX, 1000BASE-T, 1000BASE-SX, 1000BASE-LX, 1000BASE-ZX, and coarse wavelength-division multiplexing (CWDM) SFP transceivers. These ports also support the Cisco Catalyst 3560 SFP Interconnect Cable for establishing a low-cost Gigabit Ethernet point-to-point connection.

Service Provider-Friendly Hardware

Metro Ethernet access switches are typically deployed in the basements of office buildings or in apartments. Service providers are always challenged to find enough space to deploy equipment. To ease this obstacle, the purpose-built Cisco ME 3400 Series is designed with a compact form factor (1RU x 9.52 in.) and flexible mounting options. In addition, the Cisco ME 3400 Series is built with all front-accessed connectors to simplify field installation and troubleshooting. To help ensure compliance with industry standards, the Cisco ME 3400 Series has obtained both Network Equipment Building Standards Level 3 (NEBS3) and ETSI certifications.

Industry Standard Services



Carrier Ethernet is a huge growth area for emerging connectivity services. It is a comparatively simple, cost-effective, and familiar technology whose migration to the WAN will lead to more flexible network connectivity while reducing overall IT costs. However, its deployment is constrained by a shortage of global standards that provide assurance that equipment from different vendors will interoperate. In order to accelerate the adoption of Carrier Ethernet services and technology worldwide, service providers asked the Metro Ethernet Forum (MEF) to initiate a certification program to assure them and their customers that products are compliant with MEF specifications. The Cisco ME 3400 Series is certified to MEF 9 and 14 to support industry-standard Layer 2 services and QoS features.

Gigabit Ethernet

With more and more applications demanding higher bandwidth, both enterprise and residential customers are starting to demand access speeds greater than 100 Mbps. To address this requirement, the Cisco ME 3400 Series offers wire-speed Gigabit Ethernet with all the Metro Ethernet functionalities. At speeds of 1000 Mbps, Gigabit Ethernet provides the bandwidth to meet new and evolving network demands, alleviate bottlenecks, and boost performance while protecting the existing infrastructure investments.

Metro-Specific Software

The Cisco ME 3400 Series switches have software specifically designed for the Metro Ethernet market. Numerous new features are added to make the Cisco ME 3400 Series the optimal access switch for service providers. Many default behaviors of the Cisco ME 3400 Series are different from those of traditional Ethernet switches. These differences make the Cisco ME 3400 Series easier to configure, manage, secure, and troubleshoot.

UNI/NNI

The Cisco ME 3400 Series software introduces the concept of User-Network Interface/Network-Node Interface (UNI/NNI) for Ethernet access switches. Because the software can identify the application of each port, it can provide many powerful default behaviors. Table 1 lists some of the primary behaviors and benefits of UNI/NNI.

Table 1. UNI/NNI Default Behaviors

Default Behaviors	Benefits
UNI Default: Down	Ports must be activated by the service provider before customers can receive service.
UNIs Default: No Local Switching	Circuit-like behavior protects customers from each other.
UNI Default: Control Plane Security Enabled	Control-plane packets ingressing from the UNI are dropped in hardware to protect against denial of service (DoS) attacks.
NNI Default: Up	Enables automated configuration of the switch through a Dynamic Host Configuration Protocol (DHCP) or BOOTP server.

Multiple Software Feature Images to Provide Flexible Deployment Options

The Cisco ME 3400 Series switches offer three different Cisco IOS Software feature images, METROBASE, METROACCESS, and METROIPACCESS—providing cost-effective, pay-as-you-grow service upgrade options for service providers deploying multiple services. The service providers do not have to pay for the features they do not need today and still have the option in the future to receive those features with a simple software upgrade.

Support for multiple software feature images allows service providers to standardize on the Cisco ME 3400 Series switches; save on the OpEx of stocking multiple products; simplify training of support technicians; and alleviate complications in supporting different products for different services.

Table 2 lists key features in the Cisco IOS Software images for Cisco ME 3400 Series.

Table 2. Key Features in Cisco IOS Software Images for Cisco ME 3400 Series

METROBASE	METROACCESS	METROIPACCESS
UNI/NNI	METROBASE +	METROACCESS +
Internet Group Management Protocol (IGMP) Filtering and Throttling	802.1Q Tunneling, Layer 2 Protocol Tunneling (L2PT)	Static routing
Multicast VLAN Registration (MVR)	Ethernet OAM (802.1ag, 802.3ah, E-LMI)	Multi-VRF CE (VRF-lite)
Advanced QoS	Configurable per VLAN MAC Learning	Policy Based Routing
Control Plane Security	Flex-Link	RIP versions 1 and 2
Configuration File Security	Dynamic ARP Inspection, IP Source Guard	EIGRP, OSPF, and IS-IS
DHCP Snooping	Per Port Per VLAN Ingress Policing	BGPv4
Private VLAN	Link-State Tracking	NNI Configurable on All Ports

Multiple software feature images support the pay-as-you-grow deployment model.

Comprehensive Security Solution

As Metro Ethernet networks continue to expand, one of the challenges that service providers face is to provide the same level of security as other access technologies. To meet this challenge, the Cisco ME 3400 Series Switches provide the most comprehensive security solution for Ethernet access networks. By dividing security into three portions and designing features for each, the Cisco ME 3400 Series can provide complete solution at the access layer of Metro Ethernet networks. The three different areas of security that the switch addresses are subscriber security, switch security, and network security.

Subscriber security helps create protection among customers. One of the biggest concerns about using a shared device for multiple customers is how to prevent customers from affecting each other. The Cisco ME 3400 Series addresses this concern by providing features such as UNI/NNI, DHCP Snooping, Dynamic ARP Inspection, and IP Source Guard. The UNI/NNI feature creates a circuit-like behavior to separate customers' traffic from each other. DHCP Snooping, Dynamic ARP Inspection, and IP Source Guard help service providers identify each customer based on MAC, IP address, and port information. With this information, the service providers can prevent malicious users from spoofing fake addresses and launching man-in-the-middle attacks.

Switch security is about protecting the switch itself from attacks. The Cisco ME 3400 Series offers features to protect CPU and configuration files from attacks. CPU is a critical component of an Ethernet switch; it is responsible for process-control protocols such as Spanning Tree Protocol and routing updates; if CPU is under DoS attack, those control packets could be dropped, resulting in network outage. Features such as Control Plane Security and Storm Control protect the CPU against malicious attacks. Port Security is another important security feature; it allows service providers to control the number of MAC addresses each subscriber is allowed—thereby protecting against overwhelming the switch memory.

The final area of security is network security. The features designed for this area filter all incoming traffic to help ensure that only valid traffic is allowed through the switch. The Cisco ME 3400 Series switches have features such as access control lists (ACLs) and IEEE 802.1x authentication to identify the users and packets that are allowed to transmit traffic through the switch.

Table 3 gives the key features of the security solution.

Table 3. Key Features for Each Area of Comprehensive Security Solution

Subscriber Security	Switch Security	Network Security
UNI default: No Local Switching	Control Plane Security	Access control lists (ACLs)
DHCP Snooping and IP Source Guard	Storm Control	IEEE 802.1x
Dynamic ARP Inspection	Port Security	UNI default: Port down
Private VLAN	Configurable per VLAN MAC learning	Configuration File Security

Service Management Options

The Cisco ME 3400 Series offers a superior command-line interface (CLI) for detailed configuration. In addition, the switches support CiscoWorks, the Cisco CNS 2100 Series Intelligence Engine, the Cisco IP Solution Center (ISC), and the Simple Network Management Protocol (SNMP) for network-wide management. Service providers can integrate the Cisco ME 3400 Series transparently into their operations support systems (OSSs) and enable improved flow-through provisioning.

The Cisco CNS 2100 Series network device allows service providers to effectively manage a network of Cisco IOS Software devices, including the Cisco ME 3400 Series. It is a completely self-contained unit that includes a task-oriented Web GUI, a programmable Extensible Markup Language (XML) interface, configuration template management, and an embedded repository. Network operators can use the Web GUI to quickly turn existing Cisco IOS CLI configuration files into reusable templates. The Cisco CNS 2100 Series integrates easily into existing customer OSSs or business support systems (BSSs); it can provision systems with its external repository support and the event-based Cisco IOS Software XML interface that effectively “workflow-enables” Cisco device deployment.

Cisco IP Solution Center (ISC) is a family of intelligent network management applications that help reduce overall administration and management costs by providing automated resource management and rapid profile-based provisioning capabilities. It helps service providers offering Layer 2 VPN services by providing the provisioning, planning, and troubleshooting features essential to manage the entire lifecycle. Management features such as policy-based VPN, management VPN, and quality-of-service (QoS) provisioning help minimize the cost deployment of Layer 2 VPN services, and help guarantee the accuracy of service deployment.

Service providers can also manage the Cisco ME 3400 Series using SNMP versions 2 and 3. A comprehensive set of MIBs is provided for service providers to collect traffic information in the Cisco ME 3400 Series.

Ethernet Operations, Administration, Maintenance, and Provisioning

The advent of Ethernet as a metropolitan and wide-area networking technology has accelerated the need for a new set of operations, administration, maintenance, and provisioning (OAM&P) protocols. Service provider networks are large and complex with a wide user base, and they often involve different operators that must work together to provide end-to-end services to enterprise customers. As enterprise end customers demand higher availability of services, service providers must reduce the mean time to repair (MTTR) and increase service availability. Ethernet OAM&P features address these challenges and enable service providers to offer carrier-grade services.

The Cisco ME 3400 Series supports industry-standard OAM&P tools including 802.1ag Connectivity Fault Management and Ethernet Local Management Interface (E-LMI) protocol. 802.1ag provides the tools to monitor and troubleshoot end-to-end Ethernet networks. It allows service providers to check for end-to-end connectivity, isolate network issues, and identify customers affected by network issues. E-LMI protocol, developed by the MEF, has substantial benefits to both the service provider as well as the end customer. E-LMI enables the service provider to automatically configure the customer-edge device to match the subscribed service. This automatic provisioning not only reduces the effort to set up the service, but also reduces the amount of coordination required between the service provider and enterprise customer. In addition, Cisco ME3400 series also supports IEEE 802.3ah Ethernet in the First Mile standard for monitoring, remote failure indication, loopback, and OAM discovery on the link between the customer equipment and service provider network.

Applications

The purpose-built Cisco ME 3400 Series switches help service providers offer a portfolio of profitable, differentiated services, including Layer 2 and Layer 3 VPN services and triple-play services in both ETTB and ETTH markets.

Triple-Play Service

Triple-play service is a popular choice for service providers. By combining Internet access, voice, and video services, service providers can generate higher average revenue per unit (ARPU). Triple-play service provides additional value by increasing customer retention. The Cisco ME 3400 Series is optimized for triple-play service. By delivering the key features in the areas of QoS, multicast, and security, the Cisco ME 3400 Series helps service providers deploy successful triple-play service (Figure 2).

Figure 2. Triple-Play Service

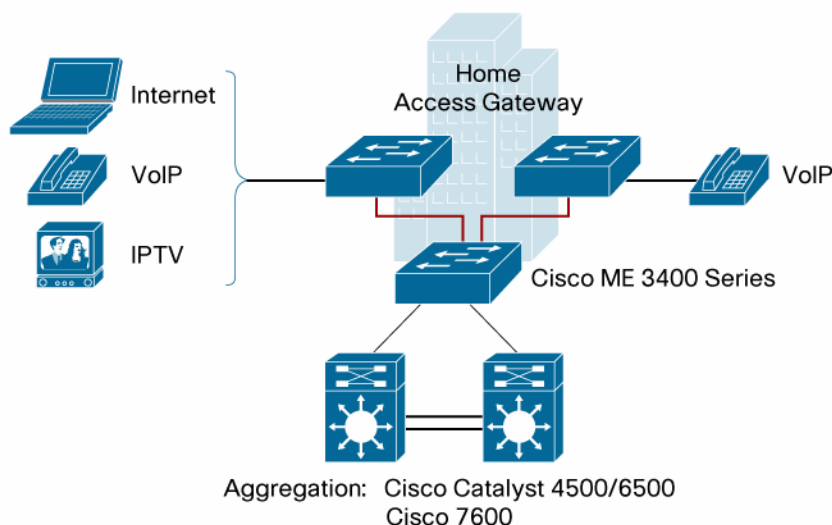

Intelligent Ethernet Demarcation

As Ethernet circuits replace TDM circuits inside of enterprise wiring closets, a replacement for the demarcation device is also needed. Service providers have traditionally relied on this type of device to separate the management responsibility. A demarcation device allows service providers to monitor and troubleshoot circuits all the way into customer's wiring closet. The Cisco ME-3400G-2CS offers the same functionalities for an Ethernet-based network. With support for industry-standard Ethernet OAM&P features, the Cisco ME-3400G-2CS allows service providers to monitor and troubleshoot Ethernet circuits remotely. This greatly reduces OpEx for service providers by reducing the numbers of site visits needed to troubleshoot network problems. In addition, the Cisco ME-3400G-2CS provides the same intelligent features such as QoS, Ethernet security, and Multicast as other switches in the Cisco ME 3400 Series.

Layer 2 VPN Service

Layer 2 VPN services allow customers to connect remote offices together through a service provider network without requiring private connections. The Cisco ME 3400 Series is ideal for metro access deployments because it offers features such as 802.1Q Tunneling and L2PT. The Cisco ME 3400 Series helps service providers offer Layer 2 VPN services to their enterprise or commercial customers (Figure 3). Typically, these switches are installed in a multi-tenant building basement serving multiple customers in the building or at the customer premises as the customer-located equipment (CLE).

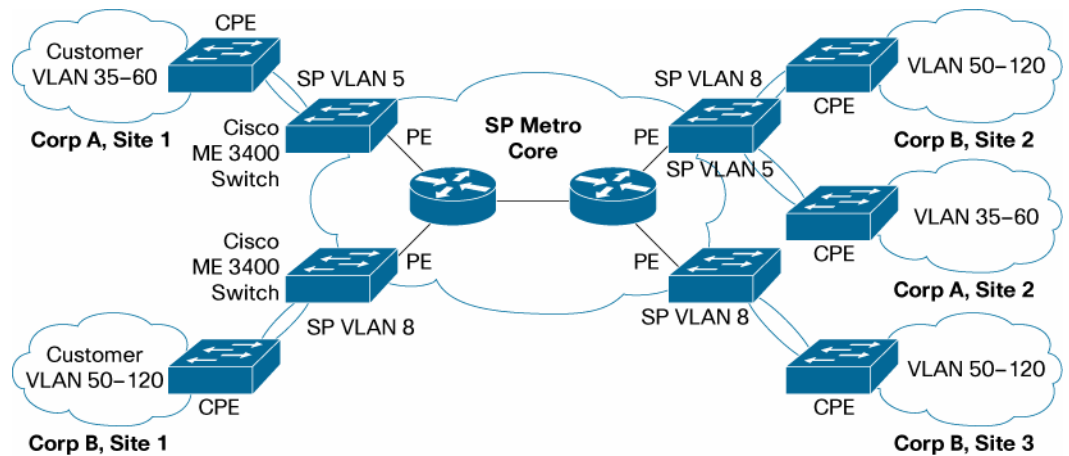
Figure 3. Layer 2 VPN Service**Layer 3 VPN Service**

With the popularity of IP technologies, Layer 3 VPN is another popular service that service providers like to offer. The benefits of Layer 3 VPN service include a single control plane over different transport technologies, advanced QoS, and security. With the Multi-VRF CE feature, the Cisco ME 3400 Series provides a separate routing-table function for each customer to help ensure separation of customers' routing information (Figure 4).

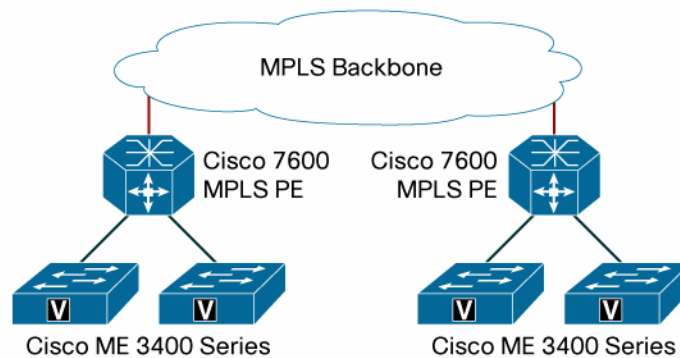
Figure 4. Layer 3 VPN Service

Key Features and Benefits

Table 4 gives features and benefits of the Cisco ME 3400 Series.

Table 4. Features and Benefits

Feature	Benefit
Purpose-Built Next-Generation Ethernet Access Switches for Metro Ethernet Market	<ul style="list-style-type: none"> All front access provides ease of deployment and troubleshooting in the field. Compact form factor (1RU x 9.52 in.) allows for deployment in space-limited areas. Dual-speed SFP transceivers support (100BASE and 1000BASE) provides flexible uplink options. Both AC and DC power options are available. Software is optimized for Metro Ethernet access. Three software feature images help enable support for breadth of services. Software upgrade options allow service providers to purchase only the features needed today while retaining the option to obtain other features through simple software upgrades. Upgrade options reduce service providers' OpEx by lowering the supporting cost for different products and also reducing the number of different products needed for sparing. METROBASE software feature image is designed for triple-play services. METROACCESS software feature image is designed for premium triple-play services or Layer 2 VPN services. METROIACCESS software feature image is designed for Layer 3 VPN services.
Service Breadth	
Triple-Play Services	<ul style="list-style-type: none"> Advanced QoS functionalities to provide differentiated class of service treatment to support triple-play service Multicast VLAN Registration (MVR) reduces overall bandwidth requirement for multicast distribution in ring based networks Comprehensive security solution to provide protection of subscribers, switch, and network at the network edge
Intelligent Ethernet Demarcation	<ul style="list-style-type: none"> Industry standard OAM&P 802.1ag (CFM) feature supports end-to-end network monitoring and troubleshooting. This greatly reduces OpEx for service providers by reducing the numbers of site visits needed to troubleshoot network problems. E-LMI enables the service provider to automatically configure the customer-edge device to match the subscribed service. Ethernet in the First Mile (EFM) OAM&P (802.3ah) provides support for monitoring, remote failure indication, loopback, and OAM discovery on the link between the customer equipment and service provider network. Support all advance layer 2, layer 3, and QoS features as other ME 3400 series switches.
Layer 2 VPN Service	<ul style="list-style-type: none"> Standard 802.1Q Tunneling creates a hierarchy of 802.1Q tags. This feature helps service providers use a single VLAN to support customers who have multiple VLANs, while preserving customer VLAN IDs and segregating traffic from different customers within the service provider infrastructure even when they appear to be on the same VLAN. L2PT allows for transport of the customers' control protocols, thereby allowing for a true virtual-circuit service across service providers' shared infrastructure.
Layer 3 VPN Service	<ul style="list-style-type: none"> Multi-VRF CE (VRF-lite) forms virtual packet-forwarding tables by associating one or more Layer 3 interfaces with each VRF, allowing the creation of multiple Layer 3 VPNs on a single Cisco ME 3400 Series Ethernet Access Switch. Interfaces in a VRF could be either physical, as in an Ethernet port, or logical, as in a VLAN switch virtual interface (SVI)—requiring the METROIACCESS Cisco IOS Software feature image. Support for multiple IP routing protocols (RIPv1/v2, EIGRP, OSPF, IS-IS, and BGPv4) offers flexible options for peering between end customers and service providers.
Availability and Scalability	
Fault Backup	<ul style="list-style-type: none"> IEEE 802.1w Rapid Spanning Tree Protocol (RSTP) provides rapid spanning-tree convergence independent of spanning-tree timers and offers the benefit of distributed processing. Per-VLAN Rapid Spanning Tree (PVRST+) allows rapid spanning-tree reconvergence on a per-VLAN spanning-tree basis, without requiring the implementation of spanning-tree instances. Cisco Hot Standby Router Protocol (HSRP) is supported to create redundant, fail-safe routing topologies.

Feature	Benefit
	<ul style="list-style-type: none"> • Unidirectional Link Detection Protocol (UDLD) and Aggressive UDLD allow unidirectional links caused by incorrect fiber-optic connections or port faults to be detected and disabled on fiber-optic interfaces. • Flex-Link provides fast failover of ports without overhead of control protocols such as the Spanning Tree Protocol. • Switch-port autorecovery (errdisable) automatically attempts to reactivate a link that is disabled because of a network error. • Equal-cost routing provides for load balancing and redundancy. • Bandwidth aggregation up to 800 Mbps through Cisco Fast EtherChannel[®] technology enhances fault tolerance and offers higher-speed aggregated bandwidth between switches and to routers and individual servers. • Link-State Tracking helps accelerate Layer 3 re-convergence by taking UNI down when the associated NNI is down.
High-Performance IP Routing	<ul style="list-style-type: none"> • Cisco Express Forwarding hardware routing architecture delivers extremely high-performance IP routing. • Basic IP Unicast routing protocols (static and RIP versions 1 and 2) are supported for small-network routing applications. • Advanced IP Unicast routing protocols (OSPF, EIGRP, IS-IS, and BGPv4) are supported for load balancing and constructing scalable LANs. • Hot Standby Router Protocol (HSRP) provides dynamic load balancing and failover for routed links; up to 32 HSRP links are supported per unit. • Inter-VLAN IP routing provides for full Layer 3 routing between two or more VLANs. • Protocol Independent Multicast (PIM) for IP Multicast routing is supported, including PIM sparse mode (PIM-SM), PIM dense mode (PIM-DM), and PIM sparse-dense mode. The Cisco IOS IP Services image is required. • Cisco recommends 128 switch virtual interfaces (SVIs). A maximum of 1000 are supported (depending on the number of routes and multicast entries).
Multicast	
Efficient Multicast Distribution	<ul style="list-style-type: none"> • Multicast VLAN Registration provides efficient multicast distribution in ring networks by dedicating a single VLAN for multicast traffic, thereby removing duplicate multicast traffic in other VLANs. • PIM-SM provides efficient routing of multicast traffic by establishing distribution trees across WANs.
Robust Multicast Control	<ul style="list-style-type: none"> • IGMP Snooping helps enable intelligent management of multicast traffic by examining IGMP messages. • IGMP Fast Leave provides a fast channel-changing capability for IPTV services. • IGMP filtering provides control of groups each user can access. • IGMP Throttling controls the maximum number of multicast groups each user can access.
QoS and Control	
Advanced QoS	<ul style="list-style-type: none"> • The Cisco Modular QoS CLI (MQC) provides a modular and highly extensible framework for deploying QoS, by standardizing the CLI and semantics for QoS features across all platforms that are supported by Cisco IOS Software. • Standard 802.1p class of service (CoS) and differentiated services code point (DSCP) field classification are provided, using marking and reclassification on a per-packet basis by source and destination IP address, source and destination MAC address, VLAN ID, or Layer 4 TCP/User Datagram Protocol (TCP/UDP) port number. • Cisco control-plane and data-plane Quality of Service (QoS) ACLs on all ports help ensure proper marking on a per-packet basis. • Shaped Round Robin (SRR) scheduling helps ensure differential prioritization of packet flows by intelligently servicing the queues. • Weighted Tail Drop (WTD) provides per QoS class congestion avoidance at the queues before a disruption occurs. • Strict priority queuing helps ensure the highest-priority packets are serviced ahead of all other traffic. • Priority queue rate limiting provides optional protection against lower priority queue starvation. • There is no performance penalty for advanced QoS functionalities.
Advanced Traffic Control	<ul style="list-style-type: none"> • Upstream and downstream traffic flows from the end station or the uplink are easily managed using ingress policing and egress shaping. • Ingress policing provides bandwidth monitoring in increments as low as 8 kbps. • Ingress policing is provided based on COS, VLAN ID, DSCP, and QoS ACLs (IP ACLs or MAC ACLs) which can include source and destination IP address, source and destination MAC address, Layer 4 TCP/UDP information, or any combination of these fields. • Egress Weighted Fair Queuing guarantees the Committed Information Rate (CIR)

Feature	Benefit
	<p>between traffic flows and queues.</p> <ul style="list-style-type: none"> Egress shaping for each queue provides smooth traffic control of available bandwidth. Egress port rate limiting allows the service provider to control the traffic rate that is transmitted out of the port.
Network Security	
Comprehensive Security Solutions	<p>Subscriber Security</p> <ul style="list-style-type: none"> IEEE 802.1x allows dynamic, port-based security by providing user authentication. IEEE 802.1x with VLAN assignment allows a dynamic VLAN assignment for a specific user regardless of where the user is connected. IEEE 802.1x and port security are provided to authenticate the port and manage network access for all MAC addresses. An absence of local switching behavior provides security and isolation between UNIs, helping ensure that users cannot monitor or access other users' traffic on the same switch. DHCP Snooping prevents malicious users from spoofing a DHCP server and sending out bogus addresses. This feature also prevents numerous other attacks such as Address Resolution Protocol (ARP) poisoning. Dynamic ARP Inspection helps ensure user integrity by preventing malicious users from exploiting the insecure nature of the ARP protocol. IP Source Guard prevents a malicious user from spoofing or taking over another user's IP address by creating a binding table between client's IP and MAC address, port, and VLAN. <p>Switch Security</p> <ul style="list-style-type: none"> Control Plane Security prevents DoS attacks on the CPU. Secure Shell (SSH) Protocol, Kerberos, and SNMPv3 provide network security by encrypting administrator traffic during Telnet and SNMP sessions. SSH, Kerberos, and the cryptographic version of SNMPv3 require a special cryptographic software image because of U.S. export restrictions. Port security secures the access to an access or trunk port based on MAC address. After a specific timeframe, the aging feature removes the MAC address from the switch to allow another device to connect to the same port. Multilevel security on the console access prevents unauthorized users from altering the switch configuration. TACACS+ and RADIUS authentication facilitate centralized control of the switch and restrict unauthorized users from altering the configuration. Configuration File Security helps ensure that only authenticated users have access to the configuration file. <p>Network Security</p> <ul style="list-style-type: none"> Cisco security VLAN ACLs on all VLANs prevent unauthorized data flows from being bridged within VLANs. Cisco standard and extended IP security router ACLs define security policies on routed interfaces for control-plane and data-plane traffic. Port-based ACLs for Layer 2 interfaces allow for application of security policies on individual switch ports. MAC address notification allows administrators to be notified of users added to or removed from the network. <p>Network Monitoring</p> <ul style="list-style-type: none"> Remote Switched Port Analyzer (RSPAN) allows for remote monitoring of the user interface. Bidirectional data support on the Switched Port Analyzer (SPAN) port allows the Cisco intrusion detection system (IDS) to take action when an intruder is detected.
Manageability	
Superior Manageability	<ul style="list-style-type: none"> The Cisco IOS CLI provides a common user interface and command set with all Cisco routers and Cisco Catalyst desktop switches. Service Assurance Agent (SAA) provides service-level management throughout the network. IEEE 802.1ag Connectivity Fault Management provides standard support for transport fault management. It allows for discovery and verification of path for Layer 2 services. Ethernet Local Management Interface enables auto configuration of CPE by CLE to support Metro Ethernet services. IEEE 802.3ah Ethernet in the First Mile provides standard support for monitoring, remote failure indication, loopback, and OAM discovery on the link between the customer equipment and service provider network. Switching Database Manager templates for Layer 2 and Layer 3 deployment allow the administrator to easily optimize memory allocation to the desired features

Feature	Benefit
	<p>based on deployment-specific requirements.</p> <ul style="list-style-type: none"> • VLAN trunks can be created from any port, using standards-based 802.1Q tagging. Up to 1005 VLANs per switch and up to 128 spanning-tree instances per switch are supported. • Four thousand VLAN IDs are supported. • RSPAN allows administrators to remotely monitor ports in a Layer 2 switch network from any other switch in the same network. • For enhanced traffic management, monitoring, and analysis, the embedded Remote Monitoring (RMON) software agent supports four RMON groups (history, statistics, alarms, and events). • Layer 2 traceroute eases troubleshooting by identifying the physical path that a packet takes from source to destination. • All nine RMON groups are supported through a SPAN port, permitting traffic monitoring of a single port, a group of ports, or the entire stack from a single network analyzer or RMON probe. • Domain Name System (DNS) provides IP address resolution with user-defined device names. • Trivial File Transfer Protocol (TFTP) reduces the cost of administering software upgrades by downloading from a centralized location. • Network Timing Protocol (NTP) provides an accurate and consistent time stamp to all intranet switches. • The Cisco ME 3400 Series supports the Cisco CNS 2100 Series Intelligence Engine and SNMP for network-wide management. • Cisco IP Solution Center (ISC) applications help reduce overall administration and management costs by providing automated resource management and rapid profile-based provisioning capabilities.
CiscoWorks Support	<ul style="list-style-type: none"> • CiscoWorks network management software provides management capabilities on a per-port and per-switch basis, providing a common management interface for Cisco routers, switches, and hubs. • SNMP versions 1, 2c, and 3 and Telnet provide comprehensive in-band management, and a CLI-based management console provides detailed out-of-band management. • Cisco Discovery Protocol versions 1 and 2 help enable automatic switch discovery for a CiscoWorks network management station. • The CiscoWorks 2000 LAN Management Solution is supported.

Product Specifications

Table 5 lists product specifications for the Cisco ME 3400 Series Ethernet Access Switches.

Table 5. Product Specifications

Description	Specification
Performance	<ul style="list-style-type: none"> • Forwarding bandwidth: <ul style="list-style-type: none"> ◦ Cisco ME 3400G-12CS AC: 32 Gbps ◦ Cisco ME 3400G-12CS DC: 32 Gbps ◦ Cisco ME 3400G-2CS AC: 8.0 Gbps ◦ Cisco ME 3400-24TS AC: 8.8 Gbps ◦ Cisco ME 3400-24TS DC: 8.8 Gbps • Forwarding rate: <ul style="list-style-type: none"> ◦ Cisco ME 3400G-12CS AC: 26 mpps ◦ Cisco ME 3400G-12CS DC: 26 mpps ◦ Cisco ME 3400G-2CS AC: 6.5 mpps ◦ Cisco ME 3400-24TS AC: 6.5 mpps ◦ Cisco ME 3400-24TS DC: 6.5 mpps • 128-MB DRAM and 32-MB flash memory • Configurable up to 8000 MAC addresses • Configurable up to 5000 unicast routes • Configurable up to 1000 IGMP groups and multicast routes • Configurable maximum transmission unit (MTU) of up to 9000 bytes, for bridging on Gigabit Ethernet ports, and up to 1998 bytes for bridging and routing on Fast Ethernet ports

Description	Specification
Connectors and Cabling	<p>10/100 Ports:</p> <ul style="list-style-type: none"> 10/100BASE-TX ports: RJ-45 connectors, 2-pair Category 5 unshielded twisted pair (UTP) cabling <p>SFP Ports:</p> <ul style="list-style-type: none"> 1000BASE-T SFP-based ports: RJ-45 connectors, 4-pair Category 5 UTP cabling, 10/100/1000 BASE-T operation in host systems with SGMII interface 100BASE-FX and -LX: Duplex LC receptacle fiber connectors (multimode and single mode) 100BASE-BX: Single-fiber LC receptacle connector (single-mode fiber) 1000BASE-BX: Single-fiber LC receptacle connector (single-mode fiber) 1000BASE-SX, -LX/LH, and -ZX and CWDM: Duplex LC receptacle fiber connectors (multimode and single-mode fiber) Cisco Catalyst 3560 SFP Interconnect Cable Management console port: RJ-45-to-DB9 cable for PC connections
Indicators	<ul style="list-style-type: none"> Per-port status LEDs: Link integrity, port disabled, and activity indications System-status LED
Dimensions (H x W x D)	<ul style="list-style-type: none"> Cisco ME 3400G-12CS AC: 1.73 x 17.5 x 11.0 in. (4.4 x 44.5 x 27.9 cm) Cisco ME 3400G-12CS DC: 1.73 x 17.5 x 11.0 in. (4.4 x 44.5 x 27.9 cm) Cisco ME 3400G-2CS AC: 1.73 x 10.6 x 7.1 in. (4.4 x 26.9 x 18.2 cm) Cisco ME 3400-24TS AC: 1.73 x 17.5 x 9.52 in. (4.4 x 44.5 x 24.2 cm) Cisco ME 3400-24TS DC: 1.73 x 17.5 x 9.52 in. (4.4 x 44.5 x 24.2 cm)
Weight	<ul style="list-style-type: none"> Cisco ME 3400G-12CS AC: 9.3 lb (4.2 kg) Cisco ME 3400G-12CS DC: 9.0 lb (4.1 kg) Cisco ME 3400G-2CS AC: 3.5 lb (1.6 kg) Cisco ME 3400-24TS AC: 6.5 lb (2.9 kg) Cisco ME 3400-24TS DC: 6.5 lb (2.9 kg)
Mean Time Between Failure (MTBF)	<ul style="list-style-type: none"> Cisco ME 3400G-12CS AC: 247,563 hours Cisco ME 3400G-12CS DC: 297,688 hours Cisco ME 3400G-2CS AC: 486,352 hours Cisco ME 3400-24TS AC: 391,823 hours Cisco ME 3400-24TS DC: 492,603 hours

Power Specifications

Table 6 gives power specifications for the Cisco ME 3400 Series.

Table 6. Power Specifications

Description	Specification
Power Consumption	<ul style="list-style-type: none"> Cisco ME 3400G-12CS AC: 65W (typical), 80W (maximum), 273 BTUs per hour Cisco ME 3400G-12CS DC: 55W (typical), 70W (maximum), 239 BTUs per hour Cisco ME 3400G-2CS AC: 15W (typical), 20W (maximum), 68 BTUs per hour Cisco ME 3400-24TS AC: 25W (typical), 30W (maximum), 102 BTUs per hour Cisco ME 3400-24TS DC: 25W (typical), 30W (maximum), 102 BTUs per hour
AC Input Voltage and Frequency	<ul style="list-style-type: none"> Cisco ME 3400G-12CS AC: 100 to 240 VAC, 1.6 to 0.8A, 50 to 60 Hz Cisco ME 3400G-2CS AC: 100 to 240 VAC, 0.5 to 0.25A, 50 to 60 Hz Cisco ME 3400-24TS AC: 100 to 240 VAC, 1.0 to 0.5A, 50 to 60 Hz
DC Input Voltages	<ul style="list-style-type: none"> Cisco ME 3400G-12CS DC: -36 to -72 VCD, 4.5 to 2.0A Cisco ME 3400-24TS DC: -36 to -72 VDC, 2.0 to 1.0A

Management and Standards

Table 7 provides management and standards support information for the Cisco ME 3400 Series.

Table 7. Management and Standards

Description	Specification
-------------	---------------

Description	Specification
Management	<ul style="list-style-type: none"> • BRIDGE-MIB (RFC1493) • BGP4-MIB (RFC1657) • CISCO-BULK-FILE-MIB • CISCO-CDP-MIB • CISCO-CONFIG-COPY-MIB • CISCO-CONF-MAN-MIB • CISCO-ENVMON-MIB • CISCO-ETHERNET-ACCESS-MIB • CISCO-FLASH-MIB • CISCO-FTP-CLIENT-MIB • CISCO-IGMP-FILTER-MIB • CISCO-HSRP-MIB • CISCO-HSRP-EXT-MIB • CISCO-PAGP-MIB • CISCO-PAE-MIB • CISCO-PING-MIB • CISCO-PRIVATE-VLAN-MIB • CISCO-PROCESS-MIB • CISCO-PORT-QOS-MIB • CISCO-PORT-SECURITY-MIB • CISCO-PORT-STORM-CONTROL-MIB • CISCO-IMAGE-MIB • CISCO-LAG-MIB • CISCO-L2L3-INTERFACE-CONFIG-MIB • CISCO-MAC-NOTIFICATION-MIB • CISCO-MEMORY-POOL-MIB • CISCO-RTTMON-MIB • CISCO-STACK-MIB • CISCO-STP-EXTENSIONS-MIB • CISCO-SYSLOG-MIB • CISCO-TCP-MIB • CISCO-UDLDP-MIB • CISCO-VLAN-IFTABLE-RELATIONSHIP-MIB • CISCO-VLAN-MEMBERSHIP-MIB • ENTITY-MIB (RFC2737) • ETHERLIKE-MIB • IEEE8021-PEA-MIB • IEEE8023-LAG-MIB • IF-MIB (RFC 1573) • IGMP-MIB • IPMROUTE-MIB • OLD-CISCO-CHASSIS-MIB • OLD-CISCO-FLASH-MIB • OLD-CISCO-INTERFACES-MIB • OLD-CISCO-IP-MIB • OLD-CISCO-SYS-MIB • OLD-CISCO-TCP-MIB • OLD-CISCO-TS-MIB • OSPF-MIB (RFC 1253) • PIM-MIB • RFC1213-MIB (MIB-II) • RMON-MIB (RFC 1757) • RMON2-MIB (RFC 2021) • SNMP-FRAMEWORK-MIB (RFC2571) • SNMP-MPD-MIB (RFC 2572) • SNMP-NOTIFICATION-MIB (RFC 2573) • SNMP-TARGET-MIB (RFC 2573) • SNMPv2-MIB (RFC 1907)
	<ul style="list-style-type: none"> • SNMP-USM-MIB (SNMP-USER-BASED-SM-MIB) (RFC2574)

Description	Specification
	<ul style="list-style-type: none"> • SNMP-VACM-MIB (SNMP-VIEW-BASED-ACM-MIB) (RFC2575) • TCP-MIB (RFC 2012) • UDP-MIB (RFC 2013)
Standards and Protocols	<ul style="list-style-type: none"> • IEEE 802.1s • IEEE 802.1w • IEEE 802.1x • IEEE 802.3ad • IEEE 802.3ah • IEEE 802.1ag • IEEE 802.3x full duplex on 10BASE-T, 100BASE-TX, and 1000BASE-T ports • IEEE 802.1D Spanning Tree Protocol • IEEE 802.1p CoS classification • IEEE 802.1Q VLAN • IEEE 802.3 10BASE-T • IEEE 802.3u 100BASE-T • IEEE 802.3ab 1000BASE-T • IEEE 802.3z 1000BASE-X • IP routing: Static, RIP versions 1 and 2, EIGRP, OSPF, BGPv4, PIM-SM, and PIM-DM (metro IP access only) • Management: SNMP versions 1, 2, and 3

Safety and Compliance

Table 8 gives safety and compliance information for the Cisco ME 3400 Series.

Table 8. Safety and Compliance



Type	Standards
Electromagnetic Emissions Compliance (EMC)	<ul style="list-style-type: none"> • FCC Part 15 Class A, • EN 55022B Class A (CISPR22 Class A) • EN 55024 • EN 300 386 • GR-1089 CORE Class A • VCCI Class I • AS/NZS 3548 Class A or AS/NZS CISPR22 Class A • MIC • CE Marking
Safety	<ul style="list-style-type: none"> • UL 60950, Third Edition • UL to CAN/CSA 22.2 No.60950, Third Edition • TUV/GS to EN 60950 with Amendment A1-A4 and A11 • CB to IEC 60950 with all country deviations • NOM to NOM-019-SCFI • AS/NZS 3260, TS001 • CE Marking • CLEI Coding
NEBS	GR-63-CORE and GR-1089-CORE—Level 3, Type 2
ETSI	EN 300 019—Storage: Class 1.2, Transportation: Class 2.3, In-Use: Class 3.2
Noise Specifications	<ul style="list-style-type: none"> • Cisco Office Product Specification: <ul style="list-style-type: none"> ◦ 48 dBA (sound pressure) ◦ 4.8 bels (sound power) • EN 300 753
Operating Environment	<ul style="list-style-type: none"> • Temperature: 0 to +50°C (temperature versus altitude curve follows NEBS specifications) • Altitude: Up to 13,000 ft (4000m) • Relative humidity: 5 to 95% noncondensing
Storage Environment	<ul style="list-style-type: none"> • Temperature: -40 to 70°C • Altitude: 15,000 ft (4570m)

Ordering Information

Table 9 lists the ordering information for the Cisco ME 3400 Series. To place an order, visit the Cisco Ordering Home Page at:

http://www.cisco.com/en/US/ordering/or13/or8/order_customer_help_how_to_order_listing.html

Table 9. Ordering Information

Part Number	Description
ME-3400G-12CS-A 	<ul style="list-style-type: none"> • 12 dual-purpose (10/100/1000 and SFP) ports • 4 SFP-based Gigabit Ethernet and 100BASE-X ports • Dual fixed redundant AC power supplies • 26-mpps forwarding rate • 1RU multilayer switch • Purpose-built Gigabit Ethernet access switch for the Metro Ethernet market • 3 Cisco IOS Software feature image options (METROBASE, METROACCESS, and METROIPACCESS)
ME-3400G-12CS-D 	<ul style="list-style-type: none"> • 12 dual-purpose (10/100/1000 and SFP) ports • 4 SFP-based Gigabit Ethernet and 100BASE-X ports • Dual fixed redundant DC power supplies • 26-mpps forwarding rate • 1RU multilayer switch • Purpose-built Gigabit Ethernet access switch for the Metro Ethernet market • 3 Cisco IOS Software feature image options (METROBASE, METROACCESS, and METROIPACCESS)
ME-3400G-2CS-A 	<ul style="list-style-type: none"> • 2 dual-purpose (10/100/1000 and SFP) ports • 2 SFP-based Gigabit Ethernet and 100BASE-X ports • AC power supplies • 6.5-mpps forwarding rate • 1RU small form-factor multilayer switch • Purpose-built intelligent Ethernet demarcation switch • 3 Cisco IOS Software feature image options (METROBASE, METROACCESS, and METROIPACCESS)
ME-3400-24TS-A	<ul style="list-style-type: none"> • 24 Ethernet 10/100 ports • 2 SFP-based Gigabit Ethernet and 100BASE-X ports • AC power supply • 6.5-mpps forwarding rate • 1RU multilayer switch • Purpose-built Ethernet access switch for the Metro Ethernet market • 3 Cisco IOS Software feature image options (METROBASE, METROACCESS, and METROIPACCESS)
ME-3400-24TS-D	<ul style="list-style-type: none"> • 24 Ethernet 10/100 ports • 2 SFP-based Gigabit Ethernet and 100BASE-X ports • DC power supply • 6.5-mpps forwarding rate • 1RU multilayer switch • Purpose-built Ethernet access switch for the Metro Ethernet market • 3 Cisco IOS Software feature image options (METROBASE, METROACCESS, and METROIPACCESS)
S340XB-12225SEG1	<ul style="list-style-type: none"> • Cisco ME 3400 Series METROBASE software feature image • Standard Layer 2 feature image targeted for triple-play services • Advance QoS: Ingress policing and egress shaping • Robust multicast: IGMP filtering and throttling, and MVR • Complete security: UNI/NNI, Control Plane Security, and Configuration File Security
S340XA-12225SEG1	<ul style="list-style-type: none"> • Cisco ME 3400 Series METROACCESS software feature image • Enhanced Layer 2 feature images targeted for premium triple-play services and Layer 2 VPN services • Advance Layer 2 Tunneling: 802.1q tunneling and L2PT • Industry-standard Layer 2 management: 802.1ag (CFM) and E-LMI • Fast convergence: Flex-Link, Link-state Tracking

Part Number	Description
S340XI-12225SEG1	<ul style="list-style-type: none"> • Cisco ME 3400 Series METROIPACCESS software feature image • Layer 3 feature images targeted for Layer 3 VPN services • IP routing (RIP versions 1 and 2, EIGRP, OSPF, IS-IS, and BGPv4) • Secured Layer 3: Multi-VRF CE • Enhanced routing: Policy Based Routing
CD-ME3400-B2A=	METROACCESS image upgrade kit for Cisco ME 3400 Series switches with METROBASE image
CD-ME3400-B2I=	METROIPACCESS image upgrade kit for Cisco ME 3400 Series switches with METROBASE image
CD-ME3400-A2I=	METROIPACCESS image upgrade kit for Cisco ME 3400 Series switches with METROACCESS image
RCKMNT-1RU=	Spare rack-mount kit for the Cisco Catalyst 3750-24TS, Catalyst 3750-48TS, and Catalyst 3750G-24T
RCKMNT-REC-1RU=	1RU recessed rack-mount kit for the Cisco Catalyst 2970, Catalyst 3550, and Catalyst 3750
RCKMNT-ETSI-1RU=	ETSI rack-mount kit for Cisco ME 3400 Series products
RCKMNT-23IN-1RU=	23-in. NEBS rack-mount kit for Cisco ME Series products
GLC-LH-SM=	Gigabit Ethernet SFP, LC connector, and LH transceiver
GLC-SX-MM=	Gigabit Ethernet SFP, LC connector, and SX transceiver
GLC-ZX-SM=	Gigabit Ethernet SFP, LC connector, and ZX transceiver
GLC-T=	Gigabit Ethernet SFP, RJ-45 connector, and 10/100/1000BASE-T transceiver
GLC-BX-D=	1000BASE-BX10 SFP module for single-strand SMF, 1490-nm TX/1310-nm RX wavelength
GLC-BX-U=	1000BASE-BX10 SFP module for single-strand SMF, 1310-nm TX/1490-nm RX wavelength
GLC-FE-100FX=	100BASE-FX SFP for Fast Ethernet port
GLC-FE-100LX=	100BASE-LX SFP for Fast Ethernet port
GLC-FE-100BX-U=	100BASE-BX10-U SFP
GLC-FE-100BX-D=	100BASE-BX10-D SFP
GLE-GE-100FX=	100BASE-FX (multimode fiber) (works in "multi-speed" Gigabit Ethernet SFP ports of other Cisco platforms such as the Cisco Catalyst 3560, Catalyst 3750 (non-metro), and Catalyst 2970)
CWDM-SFP-1470=	Cisco CWDM SFP, 1470 nm; Gigabit Ethernet and 1-/2-GB Fibre Channel (gray)
CWDM-SFP-1490=	Cisco CWDM SFP, 1490 nm; Gigabit Ethernet and 1-/2-GB Fibre Channel (violet)
CWDM-SFP-1510=	Cisco CWDM SFP, 1510 nm; Gigabit Ethernet and 1-/2-GB Fibre Channel (blue)
CWDM-SFP-1530=	Cisco CWDM SFP, 1530 nm; Gigabit Ethernet and 1-/2-GB Fibre Channel (green)
CWDM-SFP-1550=	Cisco CWDM SFP, 1550 nm; Gigabit Ethernet and 1-/2-GB Fibre Channel (yellow)
CWDM-SFP-1570=	Cisco CWDM SFP, 1570 nm; Gigabit Ethernet and 1-/2-GB Fibre Channel (orange)
CWDM-SFP-1590=	Cisco CWDM SFP, 1590 nm; Gigabit Ethernet and 1-/2-GB Fibre Channel (red)
CWDM-SFP-1610=	Cisco CWDM SFP, 1610 nm; Gigabit Ethernet and 1-/2-GB Fibre Channel (brown)
CSS5-CABLX-LCSC=	Cisco CSS 11500 Series Content Services Switch, 10m single-mode fiber, LX LC-to-SC connectors
CSS5-CABSX-LC=	Cisco CSS 11500 10m multimode fiber, SX LC connectors
CSS5-CABSX-LCSC=	Cisco CSS 11500 10m multimode fiber, SX LC-to-SC connectors
CAB-SFP-50CM=	Cisco Catalyst 3560 SFP Interconnect Cable (50 cm)
CAB-SM-LCSC-1M	1m single-mode fiber, LC-to-SC connectors
CAB-SM-LCSC-5M	5m single-mode fiber, LC-to-SC connectors
CAB-MCP-LC=	Mode-conditioning patch cable; LC connector

Service and Support

Cisco Systems® offers a wide range of services programs to accelerate customer success. These innovative services programs are delivered through a unique combination of people, processes, tools, and partners, resulting in high levels of customer satisfaction. Cisco services help you protect your network investment, optimize network operations, and prepare your network for new applications to extend network intelligence and the power of your business. For more information about Cisco services, refer to [Cisco Technical Support Services](#) or [Cisco Advanced Services](#).

Cisco is committed to minimizing TCO. Cisco offers a portfolio of technical support services to help ensure that Cisco products operate efficiently, remain highly available, and benefit from the most up-to-date system software. The services and support programs described in Table 10 are available as part of the Cisco Metro Ethernet Switching Service and Support solution, and are available directly from Cisco and through resellers.

Table 10. Service and Support

Service and Support	Features	Benefits
Advanced Services		
Cisco Total Implementation Solutions (TIS), available directly from Cisco Cisco Packaged TIS, available through resellers	<ul style="list-style-type: none"> • Project management • Site survey, configuration, and deployment • Installation, test, and cutover • Training • Major moves, adds, and changes • Design review and product staging 	<ul style="list-style-type: none"> • Supplement existing staff • Help ensure functions meet needs • Mitigate risk
Cisco SP Base Support and Service Provider-Based Onsite Support, available directly from Cisco Cisco Packaged Service Provider-Based Support, available through resellers	<ul style="list-style-type: none"> • 24-hour access to software updates • Web access to technical repositories • Telephone support through the Cisco Technical Assistance Center (TAC) • Advance Replacement of hardware parts 	<ul style="list-style-type: none"> • Facilitate proactive or expedited problem resolution • Lower TCO by taking advantage of Cisco expertise and knowledge • Minimize network downtime



Americas Headquarters
 Cisco Systems, Inc.
 170 West Tasman Drive
 San Jose, CA 95134-1706
 USA
www.cisco.com
 Tel: 408 526-4000
 800 553-NETS (6387)
 Fax: 408 527-0688

Asia Pacific Headquarters
 Cisco Systems, Inc.
 16B Robinson Road
 #29-01 Capital Tower
 Singapore 068912
www.cisco.com
 Tel: +65 6317 7777
 Fax: +65 6317 7768

Europe Headquarters
 Cisco Systems International BV
 Heesterbergpark
 Heesterbergweg 13-19
 1101 CH Amsterdam
 The Netherlands
www-europe.cisco.com
 Tel: +31 0 20 620 0791
 Fax: +31 0 20 557 1100

Cisco has more than 200 offices worldwide. Addresses, phone numbers, and fax numbers are listed on the Cisco Website at www.cisco.com/go/offices.

©2007 Cisco Systems, Inc. All rights reserved. CCVP, the Cisco logo, and the Cisco Square Bridge logo are trademarks of Cisco Systems, Inc.; Changing the Way We Work, Live, Play, and Learn is a service mark of Cisco Systems, Inc.; and Access Registrar, Aironet, BPX, Catalyst, CCDA, CCDP, CCIE, CCIP, CCNA, CCNP, CCSP, Cisco, the Cisco Certified Internetwork Expert logo, Cisco IOS, Cisco Press, Cisco Systems, Cisco Systems Capital, the Cisco Systems logo, Cisco Unity, Enterprise/Solver, EtherChannel, EtherFast, EtherSwitch, Fast Step, Follow Me Browsing, FormShare, GigaDrive, GigaStack, HomeLink, Internet Quotient, IOS, IPona, IPTV, iQ Expertise, the iQ logo, iQ Net Readiness Scorecard, iQuick Start, LightStream, Linksys, MeetingPlace, MGX, Networking Academy, Network Registrar, Packet, PIX, ProConnect, RateMUX, ScriptShare, SliceCast, SMARTnet, StackWise, The Festos, Way to Increase Your Internet Quotient, and TransPath are registered trademarks of Cisco Systems, Inc. and/or its affiliates in the United States and certain other countries.

All other trademarks mentioned in this document or Website are the property of their respective owners. The use of the word partner does not imply a partnership relationship between Cisco and any other company. (8761R)