



Cisco Catalyst 3750 Metro Series Switches

Product Overview

The Cisco® Catalyst® 3750 Metro Series switches are a new line of premier, customer-located switches that bring greater intelligence for Metro Ethernet access, enabling the delivery of more differentiated Metro Ethernet services. The switches feature bidirectional hierarchical quality of service (QoS) and traffic shaping, intelligent 802.1Q tunneling, VLAN translation, Multiprotocol Label Switching (MPLS), Ethernet over MPLS (EoMPLS), and Hierarchical Virtual Private LAN Service (H-VPLS) support and redundant AC or DC power. They are ideal for service providers seeking to deliver profitable business services, such as Layer 2, Layer 3, and MPLS VPNs, in several bandwidths and with different service-level agreements (SLAs). With flexible software options, the Cisco Catalyst 3750 Metro Series offers providers a cost-effective path for meeting current and future service requirements from enterprises and commercial businesses.

As an addition to the Cisco Metro Ethernet access switching portfolio, which includes the industry-leading Cisco Catalyst 3550 and Cisco Catalyst 2950 series intelligent Ethernet switches, as well as the new Cisco ME 3400 Metro Ethernet Access Switches, the Cisco Catalyst 3750 Metro Series provides enhanced QoS, broader Layer 2 and Layer 3 VPN offerings, and power redundancy for carrier-class Metro Ethernet services with service-quality guarantees. By using Cisco Catalyst 3750 Metro Series switches for metro access along with Cisco Catalyst 6500 and 4500 series switches and Cisco 7600 Series routers in the aggregation/core layers, service providers are able to build a flexible, integrated network with intelligence from end to end.

Flexible Configurations for Cost-Effective Service Deployment over Time

The Cisco Catalyst 3750 Metro Series includes the following configuration:

- Cisco Catalyst 3750 Metro Series Switch—24 10/100 ports plus two Small Form-Factor Pluggable (SFP)-based Gigabit Ethernet ports and two SFP-based Enhanced Services (ES) ports; AC or DC power required; integrated redundant power option; IP Base feature license; one rack unit (RU)

The built-in Gigabit Ethernet and ES ports accommodate a range of SFP gigabit interface converters, including 1000BASE-T, 1000BASE-SX, 1000BASE-LX/LH, and 1000BASE-ZX SFPs and coarse wavelength-division multiplexing (CWDM) SFPs. The industry-standard Cisco SFP Gigabit Interface Converter is a hot-swappable input/output device that plugs into a Gigabit Ethernet port or slot, linking the port with the network.

The ES ports support enhanced features such as bidirectional Hierarchical QoS and Traffic Shaping, intelligent 802.1Q tunneling, VLAN translation, MPLS, EoMPLS, and H-VPLS. These ports can serve as uplinks to metro aggregation points, including the Cisco Catalyst 4500 and Catalyst 6500 series and the Cisco 7600 Series, and they provide greater intelligence at the network edge.

Cisco Catalyst 3750 Metro Series switches are shipped with the Metro IP Base Software license. The license includes Layer 2 switching and basic routing such as static routing, Routing Information Protocol (RIP), intelligent 802.1Q tunneling, VLAN translation, and bidirectional hierarchical QoS.

For greater service breadth and network flexibility, Cisco Catalyst 3750 Metro Series switches offer additional software feature licenses that provide a cost-effective “pay-as-you-grow” service upgrade path. With the software feature license options on the Cisco Catalyst 3750 Metro Series, service providers are able to maximize the return on investment (ROI) for their Metro Ethernet networks by adding features as their profitability increases and service offerings expand.

The following optional software feature licenses are available on the Cisco Catalyst 3750 Metro Series (see Figure 1):

- Cisco Catalyst 3750 Metro Advanced IP Feature license (MPLS, EoMPLS, MPLS VPN; also includes the Cisco Catalyst 3750 Metro IP Services license and IP Base license)
- Cisco Catalyst 3750 Metro IP Services Feature license (Border Gateway Protocol [BGP], Enhanced Interior Gateway Routing Protocol [EIGRP], Open Shortest Path First [OSPF], Intermediate System-to-Intermediate System [IS-IS], policy-based routing [PBR], multi-VRF CE, HSRP, PIM, and DVMRP tunneling; also includes IP Base license)
- Upgrade license from Cisco Catalyst 3750 Metro IP Services to Advanced IP Services (requires IP Service Feature license)

Figure 1
Cisco Catalyst 3750 Metro Series Switches for Metro Ethernet Access



Applications

VPNs allow customers at different locations to exchange information through a service provider network, without requiring private connections. The Cisco Catalyst 3750 Metro Series is ideal for service provider Metro Ethernet access deployments, allowing providers to offer Layer 2 or Layer 3 VPN services to their enterprise or commercial customers. Typically, Cisco Catalyst 3750 Metro Series switches are installed in a building basement serving many customers in the building or at the customer premises as the customer-located equipment (CLE).

Figure 2 shows a deployment example using the Cisco Catalyst 3750 Metro Series for Layer 2 VPN service.

Figure 2
Layer 2 VPN on the Cisco Catalyst 3750 Metro Series

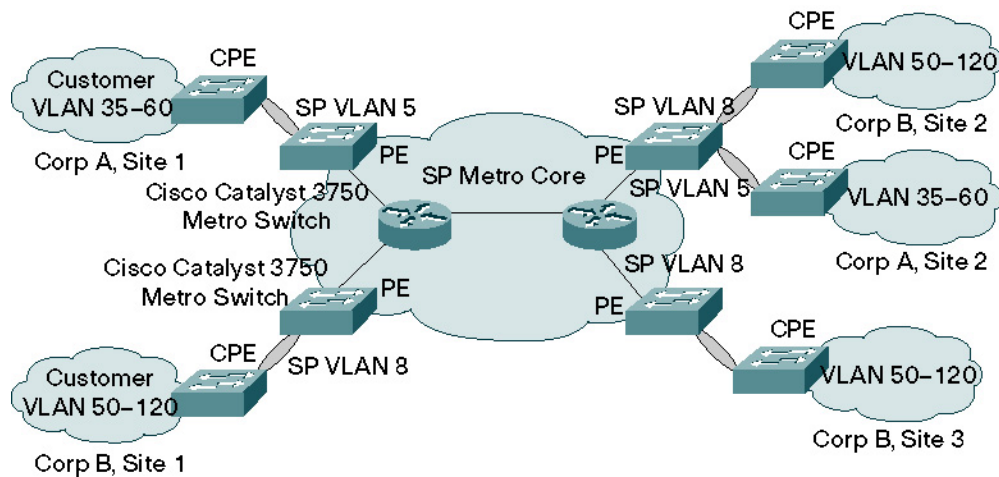

Figure 3 shows a network example of using the Cisco Catalyst 3750 Metro Series for Layer 3 MPLS VPN service.

Layer 2 VPN Using EoMPLS

EoMPLS is a tunneling mechanism that allows service providers to tunnel customer Layer 2 traffic through a Layer 3 MPLS network. This gives the service provider the best of both worlds—a Layer 2 TLS offering and the scalability of an MPLS core without needing a spanning tree. The Cisco Catalyst 3750 Metro Series supports EoMPLS on a per-port or per-VLAN basis, enabling service providers to build an end-to-end MPLS network all the way to the CLE.

Layer 2 VPN with H-VPLS architecture

VPLS is a multipoint Layer 2 VPN technology that allows multiple sites to be connected over a simulated Ethernet broadcast domain that is supported across a provider-provisioned MPLS network. H-VPLS is one of IETF's VPLS standards that provides an MPLS-based distributed-PE architecture. H-VPLS has two design options:

- **Ethernet access network**—Access networks are 802.1Q networks, and the core network is MPLS.
- **MPLS access network**—Access networks and the core network are both MPLS.

The Cisco Catalyst 3750 Metro Series supports both architecture options as the PE-CLE switch in the H-VPLS access network.

Layer 3 VPN Using Multi-VRF CE

Multi-Virtual Routing and Forwarding Customer Edge (Multi-VRF CE), also called VRF-lite, on the Cisco Catalyst 3750 Metro Series enables the creation of a Layer 3 VPN service by keeping separate routing tables for each VPN customer without needing to run MPLS on the switch. Multi-VRF CE is a feature that allows a service provider to support two or more VPNs on a single Cisco Catalyst 3750 Metro Series switch, where IP addresses can be overlapped among the VPNs. Multi-VRF CE uses input interfaces to distinguish routes for different VPNs and forms virtual packet-forwarding tables by associating one or more Layer 3 interfaces with each VRF.

Layer 3 VPN Using MPLS VPN

The Cisco Catalyst 3570 Metro Series supports MPLS VPNs, allowing service providers to build true end-to-end MPLS networks and to offer MPLS VPN services to their enterprise and commercial customers. The MPLS VPN model is a true peer VPN model that enforces traffic separations by assigning unique VRFs to each customer's VPN. Thus, users in a specific VPN cannot see traffic outside of that VPN. Traffic separation occurs without tunneling or encryption because it is built directly into the network.

Utmost SLA Support Using Traffic Shaping and Bidirectional Hierarchical Quality of Service (Through Enhanced Services Ports)

The ability to apply QoS criteria to network traffic is essential for service provider networks. As enterprises and service providers continue the shift to a single, converged network carrying mission-critical applications over a unified multiservice (data, voice, and video) architecture, the ability to manage traffic flows and delivery terms becomes increasingly critical. As enterprises outsource their network services to service providers, they will turn to providers who have the ability to supply QoS features to help ensure that on-demand, bandwidth-intensive applications and time-sensitive, information-delivery applications receive the bandwidth necessary to maintain performance. The ability to apply QoS to customer traffic will become vital to meeting SLAs and maintaining network performance. Support for advanced QoS features will also allow service providers to create premium products and service bundles. In addition, efficient application of QoS techniques reduces overall Metro Ethernet service costs through more efficient use of network links.

Cisco Catalyst 3750 Metro Series QoS technology facilitates the management of network performance with respect to bandwidth, delay, jitter, and packet loss, which are critical to optimizing application performance and meeting SLAs. The switch supports the Cisco Hierarchical Queuing Framework (HQF), which includes traffic classification, two-rate three-color policing, Class-Based Weighted Fair Queuing (CBWFQ), Low-Latency Queuing (LLQ), and traffic shaping on the output of the enhanced services ports. The hierarchical implementation of this framework enables service providers to manage their QoS at three different levels—at the physical interface level



(enhanced services ports), the VLAN level (VLANs within each port), and marked class level (classes with each VLAN), providing the most granularity and flexibility to deliver their SLAs. In addition, congestion avoidance techniques such as Weighted Random Early Detection (WRED) and tail drop are supported to better regulate network traffic and prevent congestion.

Adding Differentiated Services over Time

Many service providers start their Metro Ethernet service portfolios by offering basic Layer 2 or Layer 3 services. As the services grow in popularity among enterprise and commercial customers and the competitive service offerings become more commonplace, it is essential that service providers broaden their service portfolios by adding more differentiated services. By providing several optional software licenses with enhanced features, Cisco Catalyst 3750 Metro Series switches enable service providers to build an intelligent network without having to incur a high initial capital expenditure (CapEx). Service providers can begin selling their Metro Ethernet services with basic features and SLAs. As their services become more profitable, they can gradually increase the service offerings by purchasing the software licenses with additional features, without the need to do costly complete equipment upgrades.

With the flexibility and scalable architecture of the Cisco Catalyst 3750 Metro Series, service providers can build a more future-proof Metro Ethernet network, and, as their Metro Ethernet services evolve, the network can be upgraded without replacing the metro access equipment.

Increased Service Availability with Redundant Power Supplies

Cisco Catalyst 3750 Metro Series switches can be equipped with an optional internal redundant power supply, available in both AC and DC versions. The internal power supply redundancy provides service providers with an immediate failover capability in the case of a power supply failure. The power redundancy decreases the chance of service outage and allows the service provider to offer an SLA with a higher level of service availability.

The power supplies of Cisco Catalyst 3750 Metro Series switches are also field replaceable and hot swappable, allowing service providers to replace a failed power supply without interrupting their customers' services. The redundant power supplies, with the flexibility features built into the Cisco Catalyst 3750 Metro Series, enable service providers to build a resilient, highly available network.

Security Across the Service Portfolio with Granular Control for the Access Environment

The Cisco Catalyst 3750 Series supports a comprehensive set of security features for connectivity and access control, including access control lists (ACLs), authentication, port-level security, and identity-based network services with 802.1X and extensions. The ACLs allow service providers to restrict unwanted traffic into their networks by denying packets based on source and destination MAC addresses, IP addresses, or TCP/User Datagram Protocol (UDP) ports. All ACL lookups are done in hardware, so forwarding and routing performance is not compromised when implementing ACL-based security in the network.

Robust Service Management Options

The Cisco Catalyst 3750 Metro Series provides outstanding service management capabilities through Cisco CNS 2100 Series Intelligence Engine support and Simple Network Management Protocol (SNMP). Service providers will be able to smoothly integrate the Cisco Catalyst 3750 Metro Series into their operations support systems (OSSs) and enable improved flow-through provisioning. The Cisco CNS 2100 Series network device allows service providers to effectively manage a network of Cisco IOS® Software devices, including the Cisco Catalyst 3750 Metro Series. It is a completely self-contained unit that includes a task-oriented Web GUI, a programmable Extensible Markup Language (XML) interface, configuration template management, and an embedded repository. For comprehensive in-band management, service providers also can manage the Cisco Catalyst 3750 Metro Series using SNMP Version 2 and Version 3, and the Telnet interface. A CLI-based management console provides detailed out-of-band management.

Product Specification

Table 1 lists product specifications.

Table 1. Product Specifications

| Description | Specification |
|-------------------------------|--|
| Performance | |
| Hardware | <ul style="list-style-type: none"> • 32 Gbps maximum forwarding bandwidth at Layer 2 and Layer 3 switching fabric • Forwarding rate: 8.55 mpps • 128 MB dynamic random-access memory (DRAM) and 32 MB Flash memory; 64 MB DRAM enhanced services port memory • Configurable up to 12,000 MAC addresses • Configurable up to 11,000 unicast routes • Configurable up to 1,000 Internet Group Management Protocol (IGMP) groups and multicast routes • Configurable maximum transmission unit (MTU) of up to 9018 bytes (Jumbo frames) for bridging on Gigabit Ethernet ports, and up to 1998 bytes for bridging and routing on Fast Ethernet ports |
| Features and Functions | |
| Layer 2 VPN | <ul style="list-style-type: none"> • Enhanced 802.1Q tunneling (Q-in-Q) with CoS mutation • SP VLAN mapping capability in 802.1Q tunneling allows service providers to selectively add different service provider VLAN tags for various services • VLAN translation • EoMPLS; requires Advanced IP Feature license • H-VPLS with 802.1Q access • H-VPLS with EoMPLS access • 1024 VLANs • 4094 VLAN IDs |
| Layer 3 VPN | <ul style="list-style-type: none"> • Multi-VRF CE (VRF-lite); requires IP Services Feature license • MPLS VPN; requires Advanced IP Feature license • 26 VRFs • 8192 MPLS labels |
| Voice/video | <ul style="list-style-type: none"> • IGMP snooping • IGMP filtering • Multicast VLAN registration (MVR) • Voice VLAN |

| Description | Specification |
|-------------|--|
| IP routing | <ul style="list-style-type: none"> • Cisco Express Forwarding hardware routing architecture • Basic IP unicast routing protocols (static, RIPv1, and RIPv2) • IPv6 routing capability in hardware • Advanced IP unicast routing protocols (OSPF, IGRP, IS-IS, EIGRP); requires IP Services Feature license • BGPv4; requires IP Services Feature license • Policy-based routing (PBR); requires IP Services Feature license • Protocol-Independent Multicast (PIM) sparse mode (SM), dense mode (DM), and sparse dense mode; requires IP Services Feature license • Distance Vector Multicast Routing Protocol (DVMRP) tunneling; requires IP Services Feature license |
| QoS | <p>ES ports</p> <ul style="list-style-type: none"> • Bidirectional Hierarchical QoS (QoS at physical interface level, VLAN level, and marked class level) • Ingress and egress traffic shaping • CBWFQ • 2 rate 3 color (CIR/EIR) rate limiting at 64 kbps increments • LLQ/priority queue • 802.1Q CoS, differentiated services code point (DSCP), IP Precedence, and MPLS EXP bits • WRED • Tail Drop (TD) • 8192 class queues • 1000 egress policers per ES port <p>Customer ports</p> <ul style="list-style-type: none"> • Shaped Round Robin (SRR) scheduling • Egress traffic shaping • LLQ/priority queue • 4 egress queues • Strict priority queuing • Per ASIC per VLAN policing • 802.1Q class of service (CoS) and differentiated services code point (DSCP) • DSCP transparency • 512 ingress policers for all customer ports • Rate limiting at 8 kbps increments • Weighted Tail Drop (WTD) |

| Description | Specification |
|--------------|--|
| Availability | <ul style="list-style-type: none"> • Redundant hot-swappable AC or DC internal power supplies • Flex links for fast failover on redundant links • 802.1w Rapid Spanning Tree Protocol • 802.1s Multiple Spanning Tree Protocol (MSTP) • Per-VLAN Spanning Tree Plus (PVST+) • Per-VLAN Rapid Spanning Tree Plus (PVRST+) • Cisco Hot Standby Router Protocol (HSRP); requires IP Services Feature license • Unidirectional Link Detection (UDLD) and aggressive UDLD • VLAN Trunking Protocol (VTP) • Per-port broadcast, multicast, and unicast storm control • Customizable Ethertype |
| Security | <ul style="list-style-type: none"> • 802.1x • DHCP snooping with the option-82 information option • Dynamic ARP Inspection • IP Source Guard • Private VLAN • SSHv2 • VLAN ACLs • Standard and extending IP security router ACLs (RACLs) • Port-based ACLs • Private VLAN edge • Port security • VLAN1 minimization • TACACS+ support • RADIUS support • MAC address notification • Secure Shell (SSH) Protocol • Kerberos • SNMPv3 • Trusted boundary • Bridge Protocol Data Unit (BPDU) guard • Spanning Tree Root Guard (STRG) • IGMP filtering |

| Description | Specification |
|--------------------------------|--|
| Management | <ul style="list-style-type: none"> • Cisco CNS 2100 Series Intelligence Engine support • SNMP v1, v2, v3 • Telnet interface • VTP • Cisco Group Management Protocol • IGMP snooping • Remote Switch Port Analyzer (RSPAN) • Embedded Remote Monitoring (RMON) software agent • DHCP relay • DHCP server • Cisco Discovery Protocol versions 1 and 2 • Layer 2 Trace Route • Domain Name System (DNS) • Trivial File Transfer Protocol (TFTP) • Network Timing Protocol (NTP) • Dynamic VLAN assignment • Multifunction LEDs per port, and multifunction LEDs for power supplies |
| Protocols and Standards | |
| Ethernet | IEEE 802.3, 10BASE-T |
| Fast Ethernet | IEEE 802.3u, 100BASE-TX, IEEE 802.3, 100BASE-FX |
| Gigabit Ethernet | IEEE 802.3z, IEEE 802.3x, IEEE 802.3ab |
| VLAN Trunking/Tagging | IEEE 802.1Q, IEEE 802.3ad |
| Spanning Tree Protocol | IEEE 802.1D, IEEE 802.1w, IEEE 802.1s |
| Security | IEEE 802.1x |
| 1000BASE-X (SFP) | 1000BASE-SX, 1000BASE-LX/LH, 1000BASE-ZX, 1000BASE-TX, CWDM SFPs |
| Management | SNMPv1, SNMPv2c, SNMPv3 |
| QoS | IEEE 802.1p |
| Routing | <ul style="list-style-type: none"> • Static, RIPv1, RIPv2; IP Base license • EIGRP, OSPF, IS-IS, PBR, multi-VRF CE; IP Services Feature license required • BGPv4; IP Services Feature license required |
| Multicast | <ul style="list-style-type: none"> • IGMP v1, v2, v3 • PIM Sparse Mode, PIM Dense Mode, PIM Sparse-Dense Mode; requires IP Services Feature license |
| Metro Ethernet Forum (MEF) | <ul style="list-style-type: none"> • MEF9 compliant |

| Description | Specification |
|---|--|
| Connectivity | |
| Connectors and cabling | <ul style="list-style-type: none"> • 10BASE-T ports: RJ-45 connectors, 2-pair Category 3, 4, or 5 unshielded twisted-pair (UTP) cabling • 100BASE-TX ports: RJ-45 connectors, 2-pair Category 5 UTP cabling • 1000BASE-T SFP-based ports: RJ-45 connectors, 2-pair Category 5 UTP cabling • 1000BASE-SX, -LX/LH, -ZX, -TX SFP-based ports: LC fiber connectors (single-mode or multimode fiber) • 100FX SFP on GE SFP ports (only non-ES SFP ports) • Management console port: RJ-45-to-DB9 cable for PC connections |
| MIBs | <ul style="list-style-type: none"> • Multiple MIBs are supported. See the Cisco Catalyst 3750 Metro Software Configuration Guide for a full listing |
| Physical Dimensions | |
| Dimensions (H x W x D) | 1.73 x 17.5 x 14.68 in. (4.39 x 44.5 x 37.3 cm) |
| Weight | 12.1 lb (5.49 kg) (Cisco Catalyst 3750 Metro 24-AC or DC) |
| Power | |
| Power consumption | 110W (maximum), 374 BTUs per hour (Cisco Catalyst 3750 Metro 24-AC or DC Switch) |
| AC input voltage and frequency | 100 to 127/200 to 240 VAC (autoranging), 50 to 60 Hz (Cisco Catalyst 3750 Metro 24-AC) |
| DC input voltage | -36 to -72 VDC @ 3A (Cisco Catalyst 3750 Metro 24-DC) |
| Approvals, Compliance, and Hardware Warranty | |
| Safety certifications | <ul style="list-style-type: none"> • UL 60950, Third Edition • UL to CAN/CSA 22.2 No.60950, Third Edition • TUV/GS to EN 60950 with Amendments A1-A4 and A11 • CB to IEC 60950 with all country deviations • NOM to NOM-019-SCFI • AS/NZS 3260, TS001 • CE Marking • CLEI Coding |
| Electromagnetic emissions certifications | <ul style="list-style-type: none"> • FCC Part 15 Class A • EN 55022B Class A (CISPR22 Class A) • GR-1089 CORE Class A • VCCI Class I • AS/NZS 3548 Class A or AS/NZS CISPR22 Class A • BSMI Class A • MIC • CE Marking |
| Network Equipment Building Standards (NEBS) | Level 3, Type 2; Cisco Catalyst 3750 Metro 24-DC and -AC |
| Noise specifications | Office product specification: 50dBA |
| Mean time between failure (MTBF) | <ul style="list-style-type: none"> • 168,231 hours (one power supply) • 256,311 hours (two power supplies) |

| Description | Specification |
|-----------------------|--|
| Operating environment | <ul style="list-style-type: none"> • Temperature: <ul style="list-style-type: none"> 0 to 45°C –5 to +55°C (NEBS short-term operation) • Altitude: up to 10,000 ft • Relative humidity: <ul style="list-style-type: none"> 10 to 85 percent noncondensing 5 to 95 percent noncondensing (NEBS short-term operation) |
| Storage environment | <ul style="list-style-type: none"> • Temperature: <ul style="list-style-type: none"> –25 to 70°C –40 to 70°C (NEBS [SHORT-TERM OPERATION]) • Altitude: 15,000 ft (4570m) |
| Warranty | 1-year limited hardware warranty |

Ordering Information

To place an order, visit the Cisco Ordering Home Page. Table 2 shows ordering information.

Table 2. Ordering Information

| Product Name | Product Part Number |
|---|---------------------|
| Cisco Catalyst 3750 Metro Switch (requires selecting at least one power supply) | ME-C3750-24TE-M |
| Cisco Catalyst 3750 Metro Switch Primary AC power supply | PWR-ME3750-AC |
| Cisco Catalyst 3750 Metro Switch Primary DC power supply | PWR-ME3750-DC |
| Cisco Catalyst 3750 Metro Switch Redundant AC power supply (optional) | PWR-ME3750-AC-R |
| Cisco Catalyst 3750 Metro Switch Redundant DC power supply (optional) | PWR-ME3750-DC-R |
| Cisco Catalyst 3750 Metro Advanced IP Feature license | ME3750-ADVIP-LIC= |
| Cisco Catalyst 3750 Metro IP Services Feature license | ME3750-IPSVCLIC= |
| Cisco Catalyst 3750 Metro IP Services to Advanced IP Upgrade license | ME3750-UPGRDLIC= |
| Cisco Catalyst 3750 Metro Switch AC power supply (spare) | PWR-ME3750-AC= |
| Cisco Catalyst 3750 Metro Switch DC power supply (spare) | PWR-ME3750-DC= |

Service and Support

Cisco offers numerous services programs to accelerate customer success. These innovative services programs are delivered through a unique combination of people, processes, tools, and partners, resulting in high levels of customer satisfaction. Cisco services help you to protect your network investment, optimize network operations, and prepare your network for new applications to extend network intelligence and the power of your business. For more information about Cisco services, see [Cisco Technical Support Services](#) or [Cisco Advanced Services](#).

For More Information

For more information about Cisco Catalyst 3750 Metro Series switches, contact your local account representative or visit <http://www.cisco.com/go/catalyst3750metro>.

**Corporate Headquarters**

Cisco Systems, Inc.
170 West Tasman Drive
San Jose, CA 95134-1706
USA
www.cisco.com
Tel: 408 526-4000
800 553-NETS (6387)
Fax: 408 526-4100

European Headquarters

Cisco Systems International BV
Haarlerbergpark
Haarlerbergweg 13-19
1101 CH Amsterdam
The Netherlands
www-europe.cisco.com
Tel: 31 0 20 357 1000
Fax: 31 0 20 357 1100

Americas Headquarters

Cisco Systems, Inc.
170 West Tasman Drive
San Jose, CA 95134-1706
USA
www.cisco.com
Tel: 408 526-7660
Fax: 408 527-0883

Asia Pacific Headquarters

Cisco Systems, Inc.
168 Robinson Road
#28-01 Capital Tower
Singapore 068912
www.cisco.com
Tel: +65 6317 7777
Fax: +65 6317 7799

Cisco Systems has more than 200 offices in the following countries and regions. Addresses, phone numbers, and fax numbers are listed on the **Cisco Website at www.cisco.com/go/offices.**

Argentina • Australia • Austria • Belgium • Brazil • Bulgaria • Canada • Chile • China PRC • Colombia • Costa Rica
Croatia • Cyprus • Czech Republic • Denmark • Dubai, UAE • Finland • France • Germany • Greece • Hong Kong SAR
Hungary • India • Indonesia • Ireland • Israel • Italy • Japan • Korea • Luxembourg • Malaysia • Mexico
The Netherlands • New Zealand • Norway • Peru • Philippines • Poland • Portugal • Puerto Rico • Romania • Russia
Saudi Arabia • Scotland • Singapore • Slovakia • Slovenia • South Africa • Spain • Sweden • Switzerland • Taiwan
Thailand • Turkey • Ukraine • United Kingdom • United States • Venezuela • Vietnam • Zimbabwe

All contents are Copyright © 1992–2005 Cisco Systems, Inc. All rights reserved. Cisco, Cisco Systems, and the Cisco Systems logo are registered trademarks or trademarks of Cisco Systems, Inc. and/or its affiliates in the United States and certain other countries.

All other trademarks mentioned in this document or Website are the property of their respective owners. The use of the word partner does not imply a partnership relationship between Cisco and any other company. (0502R) Pa/LW9315 09/05